

KISTLER

measure. analyze. innovate.

Torque Sensors

Measurement
Instrumentation for
Test Stands and Drive
Engineering, Process
Monitoring and
Quality Assurance



Kistler – Your Partner for Efficiency and Quality

Sensors and systems from Kistler prove their versatility in multiple applications - in research and design, in testbench, drive and materials handling technologies, in operation and process monitoring as well as in production measurement technology and quality assurance. Last but not least they allow documentation of process and quality data.

From our headquarters in Switzerland, we supply assembly and testing technology as well as specific sensors and monitoring systems for combustion engines, automotive engineering, plastics processing and biomechanical engineering.

Kistler's core competency lies in the development, production and implementation of sensors for pressure, force and acceleration measurement.





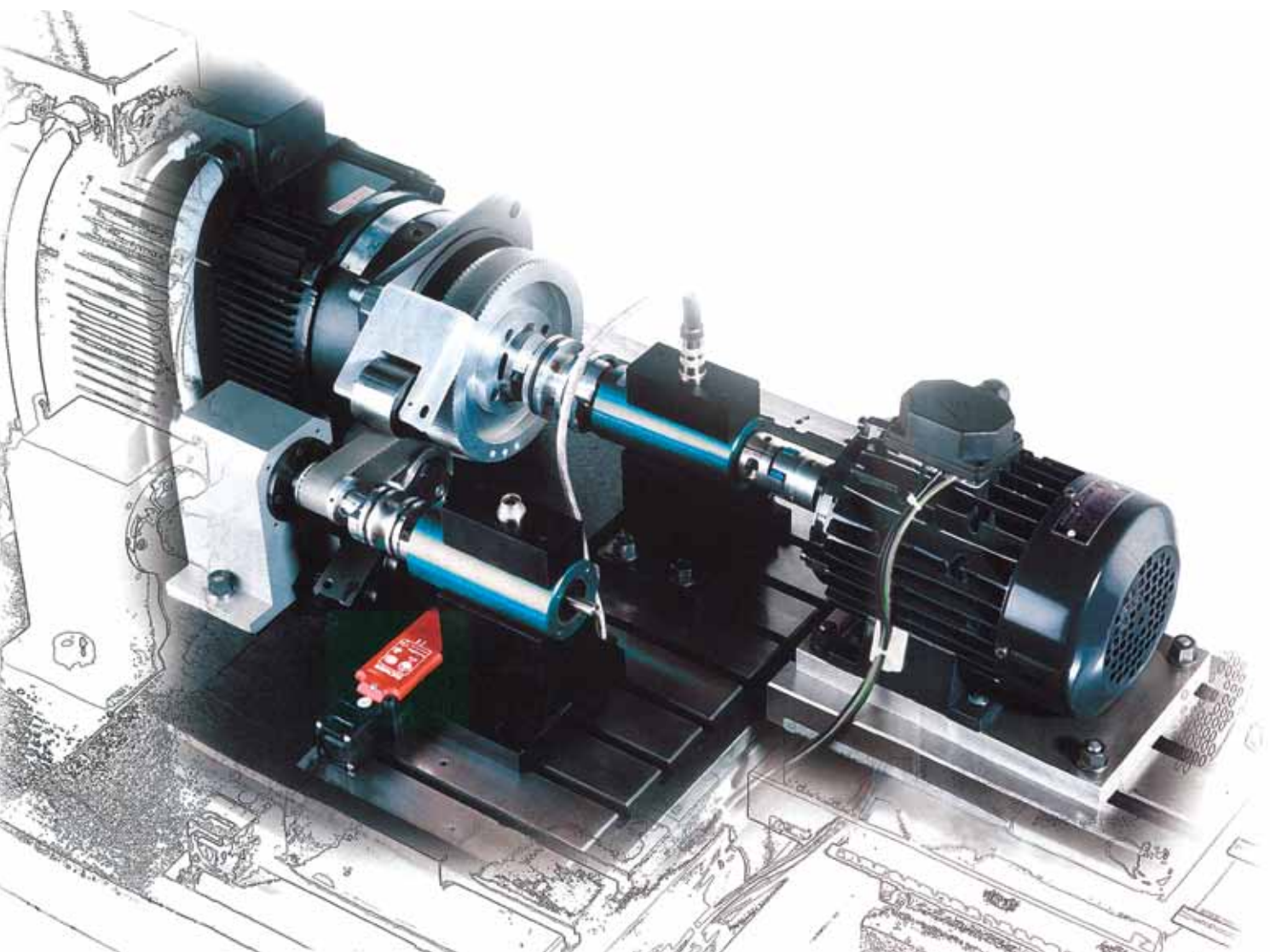

Kistler electronic systems and expertise used for conditioning measurement signals allow analysis, control and optimization of physical processes as well as enhancement of product quality for the manufacturing industry.

Year after year the company invests 10 % of its sales in R&D to facilitate technically innovative yet cost-effective state of the art solutions.

With a combined workforce of around 1050, the Kistler Group is the world market leader in dynamic measurement technology. Twenty three group companies worldwide and more than 30 distributors ensure close contact with the customer, individual application engineering support and short lead times.



Contents

Torque Measuring Technology in Practical Applications		4	
Product Overview Contents		6	
Overview Torque Sensors		8	
Details of Products/Products			
Measuring:	Sensors	10	
Amplifying:	Charge and Measuring Amplifiers	20	
Analyzing:	Monitoring Devices and Software	22	
Overview Couplings		24	
Accessories:	Couplings	26	
Connecting:	Cable/Connector	30	
Examples Typical Measuring Chains		31	
Torque Measurement Technology		32	
Basics of Piezoelectric Sensors		34	
Basics of Strain Gage Sensors		36	
Technical Literature		38	
Product Overview by Type Numbers		39	

Torque Measuring Technology in Practical Applications

Continuous close cooperation with research and industry assure constant further development of measuring technology and sensor designs. Contactless digital signal transmission from rotor to stator, integra-

ted signal conditioning as well as serial interface and standardized analog and frequency outputs make the integration into existing test systems easy for the user.

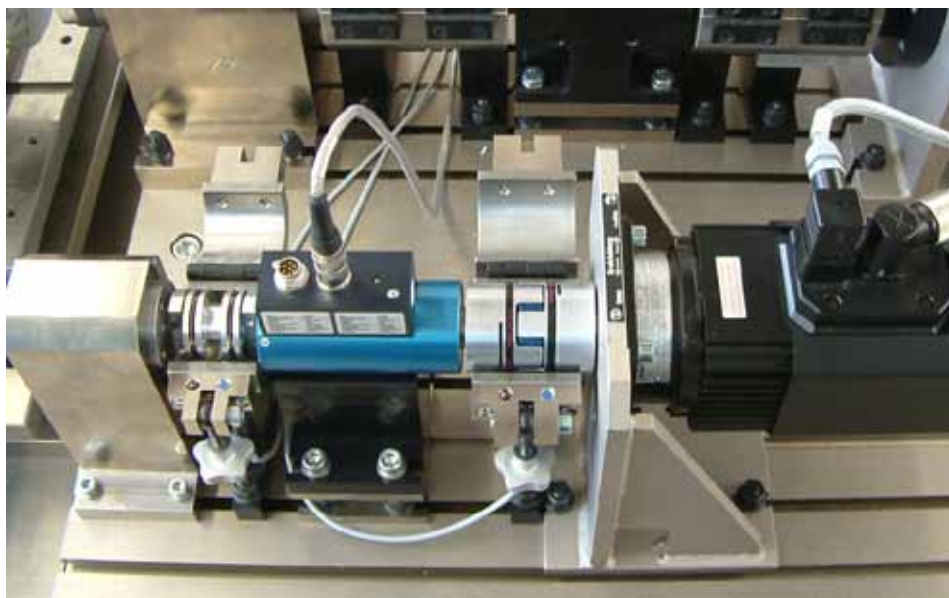

Testing Electric Motors

The mechanical and electrical characteristics, thermal design, overload capacity and other technical data of electrical machinery are subjected to intensive testing. The determination of efficiency and power factor is particularly demanding on the accuracy and flexibility of test systems. Torque sensors are of crucial importance here.

Accurate measurement of torque applied to rotating drives and components is an important criterion for effective product development and reliable quality control in production and assembly. The versatile universal torque sensor Type 4503A... caters for numerous applications across this sector.

Production Process Monitoring

Accurate measurement of torques applied to rotating drives and components is an important criterion for evaluating production efficiency and quality assurance in manufacturing and assembly. Nowadays, process monitoring demands continuous, traceable acquisition of measurement results from torque sensor systems Type 4502A..., 4520A... and 4503A... .

Examples include:

- Automatic screw connection procedures
- Viscosity monitoring
- Measurement of friction in the production testing



Research and Development

The development of internal combustion engines and gearboxes, and test stand simulation as a means of investigating drive trains, require a robust, high-precision torque sensor.

High torsion resistance and a short form factor are also required in order to map dynamic load cycles with a realistic operating profile. The torque measuring flange Type 4504B..., Type 4550A... and Type 4510B... has been specially tailored to these requirements.

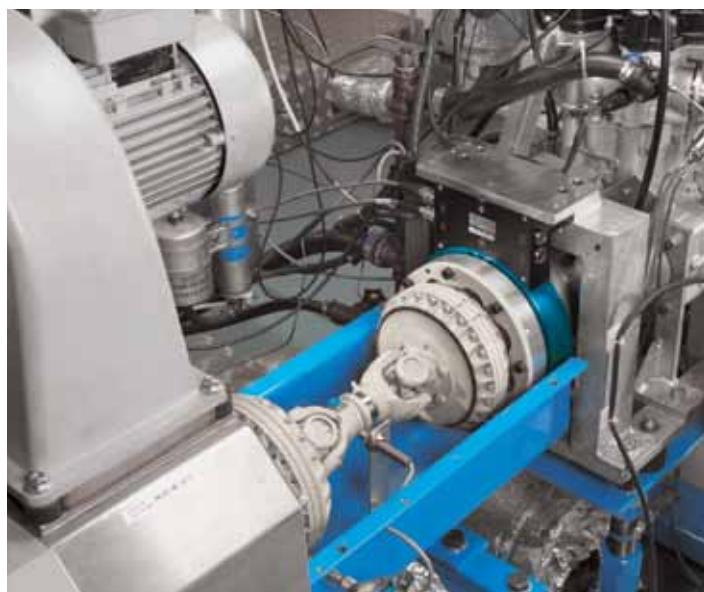

Product Testing

Each and every step in the assembly of safety-related components in the production process is monitored with sensors. Automobile suppliers can only guarantee their components will function perfectly if they test their own production as a reliable means of avoiding failures when the parts reach the customer.



Ignition Switches with Torque Sensors



The operation of fitted ignition switches can be tested as early as the production stage with the aid of torque sensors. The torques required to turn their spring-loaded components must remain within specified tolerances.





Product Overview Contents

Torque Sensors

Reaction Torque Sensors









Sensors		
Type		9039 ... 9069
Name		Torque sensor
Measuring direction		
Measuring range	N·m	-5 ... 5 to -200 ... 200
Further details on page		10

Calibrated Measuring Elements		
Type		9329A ... 9389A
Name		Reaction torque sensor
Measuring direction		
Measuring range	N·m	-1 ... 1 to -1 000 ... 1 000
Further details on page		11

2-Component- M_x/F_z -Meas. element, calibrated			
Type		9345B	9365B
Name		M_x/F_z measuring element	M_x/F_z measuring element
Measuring direction			
Measuring range F_z	kN	-10 ... 10	-20 ... 20
Meas. range M_x *	N·m	-25 ... 25	-200 ... 200
Further details on page		12	12

*) Reaction torque

Rotating Torque Sensors

Sensors					
Type		4501A...	4502A...	4520A...	4503A...
Name		Slip ring torque sensor	MiniSmart torque sensor	BasicLine torque sensor	Dual-range torque sensor
Measuring direction					
Rated torque	N·m	2 ... 1 000	0,5 ... 1 000	1 ... 1 000	0,2 ... 5 000
Further details on page		14	14	15	16

Sensors				
Type		4504B...	4510B...	4550A... KiTorq Rotor
Name		Torque measuring flange	Torque measuring flange with mounting set	KiTorq Rotor, torque measuring unit
Measuring direction				KiTorq System 
Rated torque	N·m	50 ... 5 000	100 ... 20 000	500 ... 3 000
Further details on page		17	18	19

Product Overview Contents



Couplings for Torque Sensors, Charge Amplifier, Monitoring Unit and Software

Torsion Proof Multi-Disk Coupling for Torque Measurement Flange Type 4504B...

Kupplungen				
Type	2300A...S...	2300A...F...	2300A...H...	2300A...A...
Name	Torsion proof multi-disk coupling	Torsion proof multi-disk coupling	Torsion proof multi-disk coupling	Torsion proof multi-disk coupling
Variant	with tension ring hub (variant S)	with flange (variant F)	with half-shell hub (variant H)	with tension ring hub (variant A)
Max. speed	1/min 8 000 ... 15 000	8 000 ... 15 000	3 100 ... 8 200	8 000 ... 15 000
Further details on page	26 Data sheet 2300A_000-667	26 Data sheet 2300A_000-667	26 Data sheet 2300A_000-667	26 Data sheet 2300A_000-667

Notice: Couplings for torque measuring flanges Type 4550A... und Type 4510B... on request

Torsion Proof Clamping Hub Coupling for Mounted Torque Sensors

Kupplungen			
Type	2301A...	2302A...	2303A...
Name	Bellows coupling	Torsion proof miniature coupling	Torsion proof miniature coupling
Variant	with clamping hub	single-flexible with clamping hub	double-flexible with clamping hub
Max. speed	1/min <10 000	24 000 ... 64 000	24 000 ... 64 000
Further details on page	27 Data sheet 2301A_000-673	28 Data sheet 2302A_000-671	29 Data sheet 2303A_000-672

Charge Amplifier for Piezoelectric Sensors

ICAM Charge Amplifier	
Type	5073A...
Name	ICAM industrial charge amplifier with high measuring range and peak value memory
Further details on page	20 Data sheet 5073A_000-524

Control and Monitor Unit

Supply and Evaluation System CoMo Torque	
Type	4700B...
Name	Supply and evaluation system for torque sensors
Further details on page	22 Data sheet 4700B_000-944











Strain Gage Amplifier

Measurement Amplifier	
Type	4701A...
Name	Measuring amplifier for strain gage Sensors and resistive travel sensors
Further details on page	21 Data sheet 4701A_000-621

Software

SensorTool	
Type	4706A
Name	PC software for parametrization, visualisation und analyze of torque sensor technology
Further details on page	23 Data sheet 4706A_000-626

Overview Torque Sensors

Type		Sensor		* Rated torque in N·m					
				Measuring range in N·m					
		fixed	rotating	0	1	10	100	1 000	10 000
4501A...	Slip-Ring Torque Sensor, Strain Gage 		■			2 ... 1 000*			
				0 ... ±2 to 0 ... ±1 000					
4502A...	Mini-Smart Torque Sensor, Strain Gage 		■		0,5 ... 1 000*				
				0 ... ±0,5 to 0 ... ±1 000					
4520A...	Basic Line Torque Sensor, Strain Gage 		■		1 ... 1 000*				
				0 ... ±1 to 0 ... ±1 000					
4503A...	Torque Sensor, Optional Dual-Range, Strain Gage 		■	0,2 ... 5 000*					
				0 ... ±0,2 to 0 ... ±5 000					
4504B...	Torque Measuring Flange, Strain Gage 		■			50 ... 5 000*			
				0 ... ±50 to 0 ... ±5 000					
4510B...	Torque Measuring Flange, Strain Gage 		■			100 ... 20 000*			
				0 ... ±100 to 0 ... ±20 000					
4550A... 4541A...	KiTorq Rotor KiTorq Stator Strain Gage 		■			500 ... 3 000*			
				0 ... ±500 to 0 ... ±3 000					
9329A... to 9389A...	Piezo Reaction Torque Sensor 	■		0 ... ±0,1 to 0 ... ±1 000					
9275	Piezo-Dynamometer 	■		0 ... ±20 to 0 ... ±200					
9345B... 9365B...	Piezo Force Link 	■		F _Z 0 ... ±1 kN to 0 ... ±20 kN, M _Z 0 ... ±2,5 N·m to 0 ... ±200 N·m					
9277A...	Piezo-Dynamometer 	■		0 ... ±0,5 to 0 ... ±25					

Max. speed	Signal output	Signal transmission Rotor – Stator		Bearing	Connector			
		Slip ring	Contactless		sqare drive	hex drive	round shaft	flange
<3 000 1/min	0 ... 2 mV/V	■		■	■	■	■	
12 000 1/min	0 ±5 VDC		■	■	■	■	■	
10 000 1/min	0 ±10 VDC		■	■			■	
50 000 1/min	0 ±5 VDC or 0 ±10 VDC or 100 ±40 kHz and RS-232C		■	■			■	
15 000 1/min	0 ±10 VDC or 100 ±40 kHz or 60 ±20 kHz or 10 ±5 kHz and RS-232C		■					■
12 000 1/min	0 ±10 VDC or 100 ±40 kHz and RS-232C		■					■
20 000 1/min	0 ... ±10 VDC 10 ±5 kHz or 100 ±40 kHz or 240 ±120 kHz and RS-232C/USB		■					■
–	±2 170 ... ±100 pC/N·m (depending on size)	Cable						■
–	±170 pC/N·m (depending on size)	Cable						■
–	±140 ... ±200 pC/N·m (depending on size)	Cable						■
–	±600... ±250 pC/N·m (depending on size)	Cable						■

1-Component Torque Sensors

Piezo Load Washer, $-5 \dots 5 \text{ N}\cdot\text{m}$ to $-200 \dots 200 \text{ N}\cdot\text{m}$

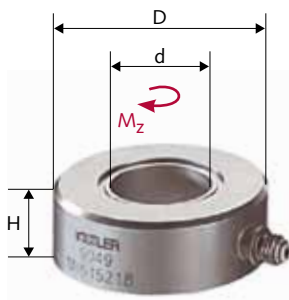

Type 9039

Technical data		Type 9039	Type 9049	Type 9069
Measuring range	N·m	-5 ... 5	-25 ... 25	-200 ... 200
Calibrated meas. ranges	N·m	0 ... -5	0 ... -25	0 ... -200
		0 ... -0,5	0 ... -2,5	0 ... -20
		0 ... 0,5	0 ... 2,5	0 ... 20
		0 ... 5	0 ... 25	0 ... 200
Sensitivity	pC/N·m	≈-600	≈-250	≈-175
Rigidity	N·m/μrad	≈7	≈12	≈50
Preloading force	kN	15	25	120
D	mm	28,5	36	52
d	mm	13	17	26,5
H	mm	11	12	15
Weight	g	38	61	150

General technical data		
Operating temp. range	°C	-150 ... 150
Deg. of protection to IEC/EN 60529		IP65 with connected cable IP67 with cable Type 1983AD... and welded connector
Connector		KIAG 10-32 neg.

Characteristics

Wide measuring range, compact design, very high rigidity, very low threshold, sturdy, welded construction.

Applications

Monitoring of torques of pneumatic screwdrivers, testing of friction clutches, measurement of motor starting torques and variations in synchronization.

Accessories

Connecting cable Type 1631C...
Preloading elements Type 9420A...

Data sheet 9039_000-111

Measuring

1-Component Torque Sensors

Piezo Reaction Torque Sensor, $-1 \dots 1 \text{ N}\cdot\text{m}$ to $-1\,000 \dots 1\,000 \text{ N}\cdot\text{m}$



Type 9329A

Technical data		Type 9329A	Type 9339A	Type 9349A	Type 9369A
Measuring range	N·m	-1 ... 1	-10 ... 10	-25 ... 25	-200 ... 200
Calibrated meas. ranges	N·m	0 ... -1	0 ... -10	0 ... -25	0 ... -200
		0 ... -0,1	0 ... -1	0 ... -2,5	0 ... -20
		0 ... 0,1	0 ... 1	0 ... 2,5	0 ... 20
		0 ... 1	0 ... 10	0 ... 25	0 ... 200
Sensitivity	pC/N·m	≈-2 170	≈-460	≈-230	≈-130
D	mm	20	30	36	54
H	mm	26	34	42	60
Weight	g	50	137	243	800
Operating temp. range	°C	-20 ... 80	-40 ... 120	-40 ... 120	-40 ... 120

Technical data		Type 9389A
Measuring range	N·m	-1 000 ... 1 000
Calibrated meas. ranges	N·m	0 ... -1 000
		0 ... -100
		0 ... 100
		0 ... 1 000
Sensitivity	pC/N·m	≈-100
D	mm	100
H	mm	130
Weight	g	6 720
Operating temp. range	°C	-40 ... 120

General technical data	
Deg. of protection to IEC/EN 60529	IP65 with connected cable IP67 with cable Type 1983AD... and welded connector
Connector	KIAG 10-32 neg.

 *These sensors are preloaded and calibrated.*

Characteristics
Compact, ready-to-mount reaction torque sensor, highly adaptable, centering seat.

Applications
Measurement of torque about the sensor axis, torque setting and testing of screw connections, calibration of manual torque wrenches, testing of spring torsion, measurements on friction clutches and electric motors, product testing of rotary controls and switches.

Accessories
Mounting flange Type 9580A...

Data sheet 9329A_000-463

2-Component Force Link

Piezo Force Link F_z , M_z

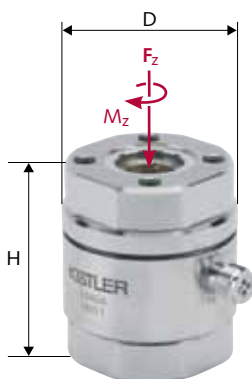

Type 9345B

Technical data		Type 9345B	Type 9365B
Measuring range F_z	kN	-10 ... 10	-20 ... 20
Calibrated meas. ranges	kN	0 ... 1	0 ... 2
		0 ... 10	0 ... 20
Sensitivity F_z	pC/N	≈3,7	≈3,6
Rigidity c_z	kN/μm	≈1,7	≈2,8
Measuring range M_z	N·m	-25 ... 25	-200 ... 200
Calibrated meas. ranges	N·m	0 ... -25	0 ... -200
		0 ... -2,5	0 ... -20
		0 ... 2,5	0 ... 20
		0 ... 25	0 ... 200
Sensitivity M_z	pC/N·m	≈-190	≈-140
Rigidity c (calculated)	N·m/μrad	≈0,19	≈0,92
D	mm	39	56,5
H	mm	42	60
Weight	g	267	834
Operating temp. range	°C	-40 ... 120	-40 ... 120
Deg. of protection to IEC/EN 60529		IP65 with connected cable	IP65 with connected cable
Connector		V3 neg.	V3 neg.

➔ These sensors are preloaded and calibrated.

Characteristics
Reaction torque sensor with option of measurement of an additional tensile/compression acting force.

Applications
Examination of the correlation between drilling torque and rupture force for PCBs, tightening torque and stripping forces in screw connections and similar processes.

Accessories
Connecting cables Types 1693A..., 1694A..., 1695A... and 1698A...

Data sheet 9345B_000-630

1-Component Torque Sensors

Piezo Dynamometer, -200 ... 200 N·m

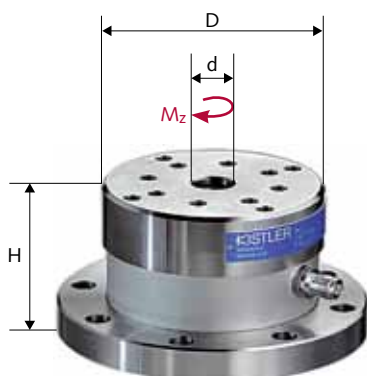

Type 9275

Technical data		Type 9275
Measuring range	N·m	-200 ... 200
Calibrated meas. ranges	N·m	0 ... -200
		0 ... -20
		0 ... 20
		0 ... 200
Sensitivity	pC/N·m	≈-170
Natural frequency	kHz	≈3,5
D	mm	100
d	mm	18,4
H	mm	70
Weight	kg	2,9
Operating temp. range	°C	0 ... 70
Deg. of protection to IEC/EN 60529		IP65 with connected cable
Connector		TNC neg.

➔ This sensor is calibrated and ready for measurement.

Characteristics
Precise, extremely high sensitivity, compact, sturdy design, non-rotating.

Applications
Testing of torque wrenches, testing of spring torsion, ergonomic measurements, testing of screw connections, measurement of starting torque of small and stepper motors.

Accessories
Connecting cable Type 1609B...

Data sheet 9275_000-154

Measuring

1-Component Torque Sensors

Piezo Dynamometer, $-5 \dots 5 \text{ N}\cdot\text{m}$, $-25 \dots 25 \text{ N}\cdot\text{m}$

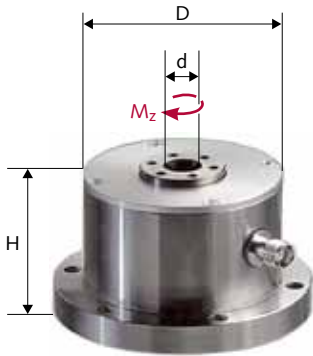

Type 9277A25

Technical data		Type 9277A5	Type 9277A25
Measuring range	N·m	$-5 \dots 5$	$-25 \dots 25$
Calibrated meas. ranges	N·m	$0 \dots -5$	$0 \dots -25$
		$0 \dots -0,5$	$0 \dots -2,5$
		$0 \dots 0,5$	$0 \dots 2,5$
		$0 \dots 5$	$0 \dots 25$
Sensitivity	pC/N·m	≈ -600	≈ -250
Natural frequency	kHz	≈ 10	≈ 15

General technical data		
D	mm	78
d	mm	8,5
H	mm	60
Weight	g	1 700
Operating temp. range	°C	$0 \dots 70$
Deg. of protection to IEC/EN 60529		IP65 with connected cable
Connector		TNC neg.

 This sensor is calibrated and ready for measurement.

Characteristics

Precise, extremely high sensitivity, high natural frequency, compact, sturdy design, non-rotating.

Applications

Testing of torque wrenches, testing of spring torsion, ergonomic measurements, testing of screw connections, measurement of starting torque of small and stepper motors.

Accessories

Connecting cable Type 1609B...

Data sheet 9277A_000-155

Rotating Torque Sensors

Slip-Ring Torque Sensor, 2 ... 1 000 N·m

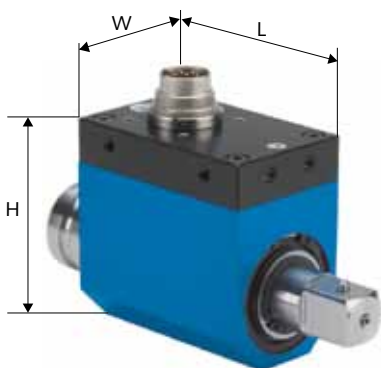

Type 4501A...

Technical data		Type 4501A...
Rated torque M_{nom}	N·m	2 / 6 / 10 / 12 / 20 / 25 / 50 / 63 / 100 / 160 / 200 / 500 / 1 000
Maximum torque		1,5 x rated torque
Accuracy class		0,2
Rated value	mV/V	1 or 2 (depending on model)
Speed measurement	pulses/rev.	2 x 360
Rated speed	1/min	≤3 000
Operating temp. range	°C	5 ... 50
Case		hard-anodized aluminum
L	mm	44 ... 73
W	mm	28 ... 73
H	mm	52 ... 90
Deg. of protection to IEC/EN 60529		IP40
Connector		Binder, 6- or 12 pin

Characteristics

All-purpose rotating torque sensor, compact, broad variety of shaft connections.

Applications

Intended specifically for use in screw driving assembly. Typical applications include testing stationary screw spindles and measuring

torque applied by hand or power tools for screw driving. For brief, intermittent measurement of torque at low speeds.

Accessories

Connector, 6 pin
Type KSM000822
Connector, 12 pin
Type KSM000703

Connecting cables

Types KSM071860-5, KSM103820-5 and KSM183150-5
Measuring amplifier for strain gage sensors Type 4701A...
See data sheet for other accessories

Data sheet 4501A_000-596

Mini-Smart Torque Sensor, 0,5 ... 1 000 N·m

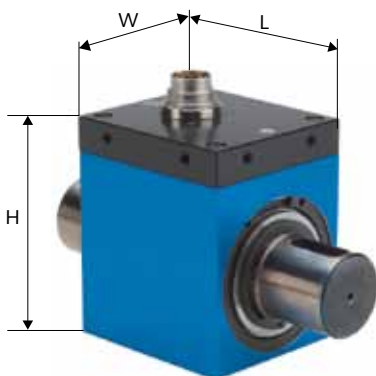

Type 4502A...

Technical data		Type 4502A...
Rated torque M_{nom}	N·m	0,5 / 1 / 2 / 5 / 6 / 10 / 12 / 18 / 20 / 50 / 63 / 100 / 150 / 160 / 200 / 250 / 300 / 500 / 1 000
Maximum torque		1,5 x rated torque
Accuracy class		0,2
Output signal at M_{nom} (rated value)	VDC	5
Speed measurement	pulses/rev.	2 x 360
Rated speed	1/min	≤12 000
Operating temp. range	°C	10 ... 60
Case		hard-anodized aluminum
L	mm	44 ... 73
W	mm	28 ... 73
H	mm	52 ... 90
Deg. of protection to IEC/EN 60529		IP40
Connector		Binder, 12 pin

Characteristics

All-purpose rotating torque sensor with non-contact signal transmission, integral electronic measuring system and high interference immunity. Compact, broad variety of shaft connections.

Applications

Suitable for dynamic measurement of tightening and unscrewing torques in screw driving and assembly as well as quality control in manufacturing and the laboratory. Suitable for continuous use, for example in process monitoring.

Accessories

Connector, 12 pin, Type KSM000703
Connecting cable
Types KSM124970-5
Couplings Types 2301A... to 2303A...
See data sheet for other accessories

Data sheet 4502A_000-597

Measuring

Rotating Torque Sensors

Basic Line Torque Sensor, 1 ... 1 000 N·m

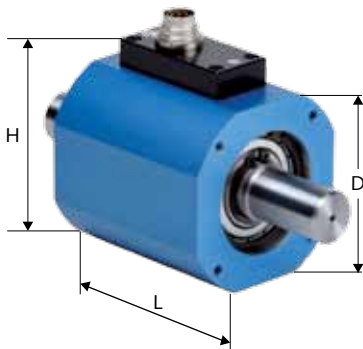

Type 4520A...

Technical data		Type 4520A...
Rated torque M_{nom}	N·m	1 / 2 / 5 / 10 / 20 / 50 / 100 / 200 / 500 / 1 000
Maximum torque		1,5 x rated torque
Alternating torque		1 x rated torque
Accuracy class		0,5
Linearity error including hysteresis	% FSO	$<\pm 0,5$
Output signal at M_{nom} (rated value)	VDC	10
Speed measurement	pulses/rev.	60
Rated speed	1/min	$\leq 10\ 000$
Operating temp. range	°C	10 ... 60
Case		hard-anodized aluminum
L	mm	58 ... 85
D	mm	58 ... 91
H	mm	70 ... 103
Deg. of protection IEC/EN 60529		IP40
Anschluss		Binder, 12 pin

Characteristics

Inexpensive torque sensor with non-contact signal transmission, with cylindrical shaft ends, robust design.

Applications

Suitable for the dynamic and static determination of torques in assembly technology and for quality control in manufacturing and in the laboratory. Suitable for continuous use, e.g. in process monitoring.

Accessories

Connector, 12 pin, Type KSM000703
Connecting cable Types KSM124970-5
Couplings Types 2301A... to 2303A...
See data sheet for other accessories

Data sheet 4520A_000-765

Rotating Torque Sensors

Torque Sensor, Optional Dual-Range, 0,2 ... 5 000 N·m



Type 4503A...

Technical data		Type 4503A...
Rated torque M_{nom}	N·m	0,2 / 0,5 / 1 / 2 / 5 / 10 / 20 / 50 / 100 / 200 / 500 / 1 000 / 2 000 / 5 000
Maximum torque		1,5 x rated torque
Alternating torque		0,7 x rated torque
Accuracy class		0,1
Linearity error including hysteresis	% FSO	<±0,1 Opt. C: <±0,05
Output signal at M_{nom} (rated value)	VDC kHz	5 or 10 or 100 ±40 and RS-232C
Speed measurement	pulses/rev.	60 oder 2 x 360
Rated speed	1/min	≤50 000
Operating temp. range	°C	10 ... 60
Case		hard-anodized aluminum or stainless steel (depending on model)
L	mm	113 ... 137
D	mm	58 ... 148
H	mm	80 ... 178
Deg. of protection to IEC/EN 60529		IP40
Connector		Binder, 7- or 12 pin

Characteristics

Sensor for two separately calibrated measuring ranges (optional). Integral electronic measuring system, maximum accuracy and extremely high speed ranges, digital signal processing. A single-range version is also available.

Applications

Universal application in the development laboratory, in manufacturing and in quality assurance.

Accessories

Connector, 7 pin
Type KSM000517
Connector, 12 pin
Type KSM000703
Connecting cables
Types KSM124970-5
and KSM219710-5
Sensor tool Type 4706A...
Couplings Types 2301A... to
2303A...
See data sheet for other accessories

Data sheet 4503A_000-595

Rotating Torque Measuring Flanges

Torque Measuring Flange, Slim, Robust, Bearingless, High Accuracy, 50 ... 5 000 N·m

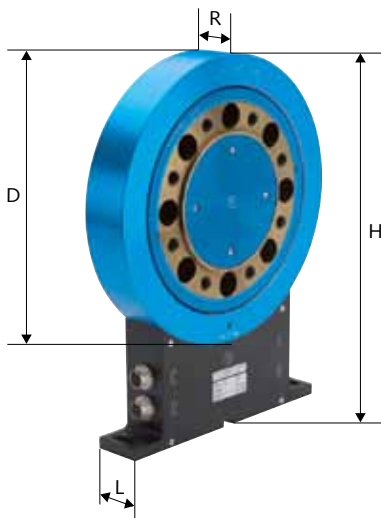

Type 4504B...

Technical data		Type 4504B...
Rated torque M_{nom}	N·m	50 / 100 / 200 / 500 / 1 000 / 2 000 / 3 000 / 5 000
Maximum torque		2 x rated torque
Alternating torque		1 x rated torque
Accuracy class		0,1
Linearity error including hysteresis	% FSO	$<\pm 0,05$
Output signal at M_{nom} (rated value)	VDC kHz	10 or 10 \pm 5, 60 \pm 20, 100 \pm 40 and RS-232C
Speed measurement	pulses/rev.	60
Speed measurement	pulses/rev.	2 x 180 ... 2 x 3 600 or 2 x 128 ... 2 x 5 120
Rated speed	1/min	$\leq 15\ 000$
Operating temp. range	°C	10 ... 60
Case		hard-anodized aluminum
L	mm	40,5 ... 64
D	mm	172 ... 311
H	mm	243,5 ... 382
R	mm	25 ... 64
Deg. of protection to IEC/EN 60529		IP54
Connector		Binder, 7-, 8- and 12 pin

Characteristics

Torque measuring flange based on the strain gage principle. Integral digital measurement conditioning system produces analog or digital output signals, which are transmitted without contact. Rotor runs in the stator ring without bearings and is free of wear.

Applications

The extremely narrow profile makes this measuring flange ideal for test stand applications including engines, gearboxes, rollers, electric motors and pumps.

Accessories

Connector, 7 pin
Type KSM000517
Connector, 12 pin
Type KSM000703
Connecting cable
Type KSM219710-5
SensorTool Type 4706A...
Couplings Types 2301A...
See data sheet for other accessories

Data sheet 4504B_000-805

Rotating Torque Measuring Flanges

Torque Measuring Flange, Robust, Bearingless, High Accuracy, 100 ... 20 000 N·m

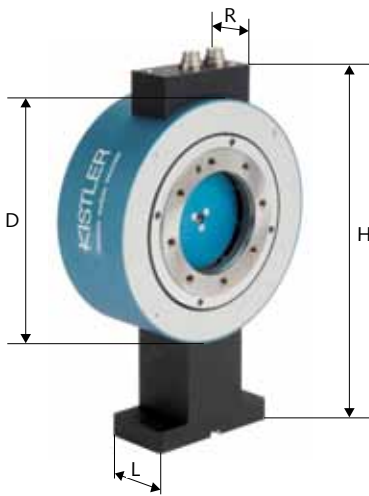

Type 4510B...

Technical data		Type 4510B...
Rated torque M_{nom}	N·m	100 / 200 / 500 / 1 000 / 2 000 / 4 000 / 10 000 / 20 000
Maximum torque		min. 1,5 x rated torque
Alternating torque		1 x rated torque
Accuracy class		≤0,2
Linearity error including hysteresis	% FSO	<±0,1 or <±0,2 (depending on model)
Output signal at M_{nom} (rated value)	VDC kHz	10 or 100 ±40 and RS-232C
Speed measurement	pulses/rev.	60
Rated speed	1/min	≤12 000
Operating temp. range	°C	10 ... 60
Case		hard-anodized aluminum
L	mm	60
D	mm	197 ... 297
H	mm	300,5 ... 362,7
R	mm	78 ... 83,5
Deg. of protection to IEC/EN 60529		IP54
Connector		Binder, 7- or 12 pin

Characteristics

Very robust torque measurement flange according to the strain gage principle with integrated speed measurement and optional switchable measuring range.

Application

Through the shaft hub connection via the shrink disc (included in the scope of delivery), the Type 4510B... can be directly connected to the drive shaft. Suitable for combustion engine, gear, roller, electric motors and pump test stands.

Accessories

Cable socket 7 pin
Type KSM000517
Cable socket 12 pin
Type KSM000703
Connector cable
Type KSM219710-5
Sensor tool Type 4706A
See data sheet for other accessories

Data sheet 4510B_000-737

Measuring

Rotating Torque Measuring Flanges

KiTorq Torque Measuring Flange, Slim, Robust, Bearingless, High Accuracy 500 ... 3 000 N·m

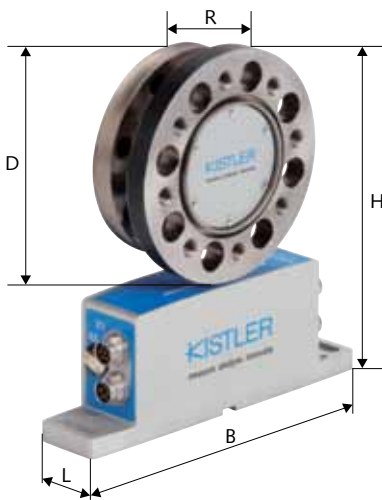

Technical data		Type 4550A... KiTorq Rotor, Type 4541A... KiTorq Stator
Rated torque M_{nom}	N·m	500 / 1 000 / 2 000 / 3 000
Maximum torque		2 x rated torque
Alternating torque		1 x rated torque
Accuracy class		0,05
Linearity error including hysteresis	% FSO	0,03
Output signal at M_{nom} (rated value)	VDC kHz	10 or 10 ±5, 100 ±40, 240 ±120 and RS-232C / USB
Speed measurement	pulses/rev.	60
Rated speed	1/min	≤20 000
Operating temp. range	°C	10 ... 60
Case		hard-anodized aluminum
L	mm	44
D	mm	133
H	mm	210,5 ... 242,5
R	mm	48 ... 53
B	mm	210
Deg. of protection to IEC/EN 60529		IP54
Connector		7-, 12- and 14 pin connector

KiTorq System

➔ For details of calibrations and special calibrations from the torque measurement chain, refer to data sheet (4541A_000-879) KiTorq Stator Type 4541A...

Characteristics
Torque measurement flange according to the strain gage principle. The analog and digital signals are transmitted without contact to the evaluation unit. The evaluation unit has 3 freely scalable outputs for the measurement signal, integrated measurement range switching and digital interface for parameterization.

Application
Its compact design and stator ring free evaluation unit makes it ideal for test stand applications and for use in confined spaces.

Accessories
Cable socket 7 pin Type KSM000517
Cable socket 12 pin Type KSM000703
Cable socket 14 pin Type KSM038290
Sensor tool Type 4706A
Couplings Type 2305A... on request
See data sheet for other accessories

**Data sheet 4541A_000-879
4550A_000-880**

Charge Amplifiers for Piezoelectric Sensors

ICAM-Programmable, Industrial Charge Amplifier



Type 5073A4...

Technical data	Type 5073A1...	Type 5073A2...	Type 5073A3...	Type 5073A4...
Number of channels	1	2	3	4

Technical data	Type 5073A5...
Number of channels	1 (charges of 4 inputs on one channel summed)

General technical data		
Number of measuring ranges		2 (switchable)
Measuring range adjustment		continuously variable
Measuring range 1 FS	pC	±100 ... 1 000 000
Measuring range 2 FS	pC	±100 ... 1 000 000
Frequency range (-3 dB)	kHz	≈0 ... 20 (±10 000 pC) ≈0 ... 2 (±1 000 000 pC)
Output signal	V mA	±10 4 ... 20 (only 5073A1... and 5073A2...)
Supply voltage	VDC	18 ... 30
Input signal	Type/connector	piezoelectric / optional BNC neg. TNC neg.
Deg. of protection to IEC/EN 60529		optional IP60 (BNC) IP65 (TNC)
Interface		RS-232C
Other features		<ul style="list-style-type: none"> · Peak memory · Adjustable output offset · Low-pass filter

M The parameters of this unit can be configured quickly and easily with the *ManuWare PC* program.

Characteristics
All-purpose industrial charge amplifier with rugged metal case; very wide variable measuring range, two independent, externally switchable measuring ranges, integral peak memory for each channel; PLC connection possible.

Applications
Monitoring, control and optimization of machinery and industrial processes.

Accessories
RS-232C null modem cable, l = 5 m, D-Sub 9 pin pos./D-Sub 9 pin neg. Type 1200A27
Cable D-Sub/15 pin neg. with flying leads one end Type 1500A41...

Data sheet 5073A_000-524

Amplifying

Strain Gage Amplifiers

Measuring Amplifier for Strain Gage Sensors, Mounted in Alu-Case



Version A



Version B and C

Technical data		Type 4701A...
Number of channels		1
Input signal	strain gage	mV/V
	resistiv	V
Cutoff frequency (-3 dB)		kHz
Output signal		V
Supply voltage		VDC
Input signal		Type/connector
Deg. of protection to IEC/EN 60529		

Version A: approx 1,5 Version B: approx 1,0 (0,5 ... 3,0, full or half bridge, max. bridge input resistance 1 000 Ω) Version C: input 0 ... 5 (input resistance 1 ... 5 kΩ)	
1	
±0 ... 5 or ±0 ... 10	
24 non-stabilized (±10 %)	
Strain gage with opt. of cable gland with soldering terminals (version A) 6 pin connector (version B)	
Version A with cable glands: IP54 Versions B and C with connectors: IP40	

Characteristics

Industrial measuring amplifier with rugged metal case. Gain and zero adjustment set with fixed resistors and potentiometers.

Applications

This amplifier is designed for industrial applications and for panel mounting. Universal measuring amplifier for strain gage sensors and resistive displacement sensors. Suitable for torque sensors Type 4501A..., strain gage force sensors Type 4576A..., Type 4577A..., Type 4578A..., Type 4579A... for displacement and key sensors Type 2112A..., Type 2117A... to Type 2121A...

Accessories

Connecting cable, 5 m, 6 pin/6 pin Type KSM071860-5
Connecting cable, 5 m, 6 pin/free Type KSM103820-5
Connecting cable, 5 m, 5 pin/5 pin Type KSM106410-5

Data sheet 4701A_000-621

Monitoring Devices

CoMo Torque Evaluation Instrument

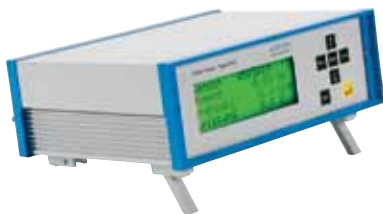

Type 4700B...

Technical data		Type 4700B...	
Number of channels $y_1 = M/t, y_2 = n/t$		2	
Signal inputs			
strain gage	mV/V	0,5 ... 3,5 (full bridge, 4/6-wire)	
active	VDC	±5 ... 10	
frequency	kHz	≤400	
Cut-off frequency (-3 dB)		kHz	0,1 ... 1
Speed / rotation angle input tracks A and B		kHz	≤300
Sensor excitation voltages		V	24 stabilized
			5 strain gage unipolar
			5 stabilized
			±12 stabilized
Output signals 3 channels		V	±10
Digital control		8 digital inputs	TTL
		8 digital outputs	TTL bzw. 24 VDC
Interfaces		RS-232C and USB 2.0	

! Compatible with SensorTool PC program for parameter configuration and evaluation

Characteristics

Universal measuring amplifier to connect passive and active force and torque sensors. Torque/speed measurements, or torque/rotation angle measurements can be evaluated. The mechanical performance is calculated and displayed by the device. The device also has digital inputs and outputs and can record extreme values and save measurement curves.

Applications

The unit is ideal for factory instrumentation and in test and laboratory environments.

Accessories

Connecting cable
 Typ KSM185350-2,5 for
 Typ 4501A... Q/R,
 Typ KSM185370-2,5 for
 Typ 4501A... QA,
 Typ KSM186420-2,5 for
 Typ 4503A.../4504... analog,
 Typ KSM186430-2,5 for
 Typ 4503A.../4504... frequency
 Typ KSM185380-2,5 for
 Typ 4502A.../4520A...

Data sheet 4700B_000-944

Analyzing

Software

SensorTool – PC Software for Setup and Evaluation of Torque Sensor Technology



Technical data	Typ 4706A
Supported equipment:	Torque sensors Types 4503A..., 4504..., 4510B..., 4550A..., CoMo Torque evaluation instrument Type 4700B... Strain Gage Meter 4703B
Further information	See data sheet

Characteristics
Configuration of instrument parameters; numerical and graphical display of measurands; evaluation of measurement values and measurement curves; reading and display of sensor and instrument data; definition of speed output pulses (magneto-resistive system in the Type 4504A...); measurement value taring; storage of recorded measurement curves in TXT or CSV format; multilingual (German/English) menu guidance.





Applications
Straightforward PC software for processing sensor and measurement data from torque sensors or evaluation systems; numerical and graphical display of all of the involved measurands (torque, speed, rotation angle, mechanical power and rotor temperature of torque sensors) on the PC screen; particularly useful during initial setup, testing or optimization; all relevant sensor data (such as serial number, sensor Type, etc.) can be displayed onscreen for a quick check of the torque sensors; defined functions can be triggered to test the sensor.

Options
None

Accessories
None

Data sheet 4706A_000-626

Overview Couplings

Couplings					
Type		2300A...S...	2300A...F...	2300A...H...	2300A...A...
Name		Torsion proof multi-disk coupling	Torsion proof multi-disk coupling	Torsion proof multi-disk coupling	Torsion proof multi-disk coupling
For Sensor		Torque Measuring Flange Type 4504...	Torque Measuring Flange Type 4504...	Torque Measuring Flange Type 4504...	Torque Measuring Flange Type 4504...
Max. speed	1/min	8 000 ... 15 000	8 000 ... 15 000	3 100 ... 8 200	8 000 ... 15 000

Notice: Couplings for torque measuring flanges Type 4550A... und Type 4510B... on request

Example of Application

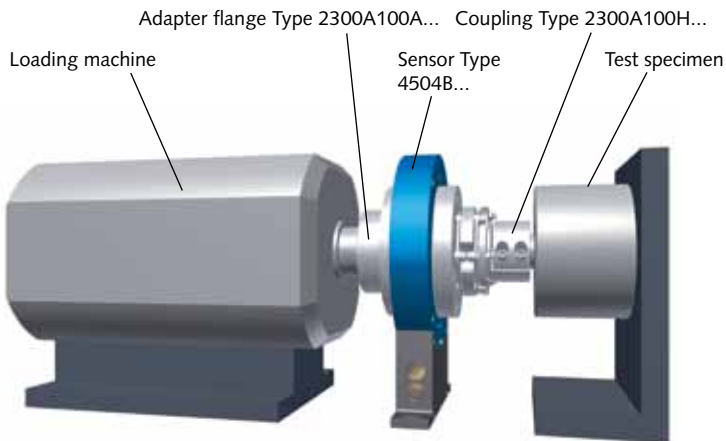

Application

The multi-disk coupling is used to compensate for axial, radial, and angle misalignment when incorporating the torque sensor into the shaft assembly. Compensation of these misalignments is always needed to avoid measurement error and damage to the sensor.

Different variants eliminate most problems integrating the torque sensor into nearly any application.

Data sheet 2300A_000-667

Included Accessories

- All necessary bolts for coupling assembly are included.

Permissible Shaft Displacements

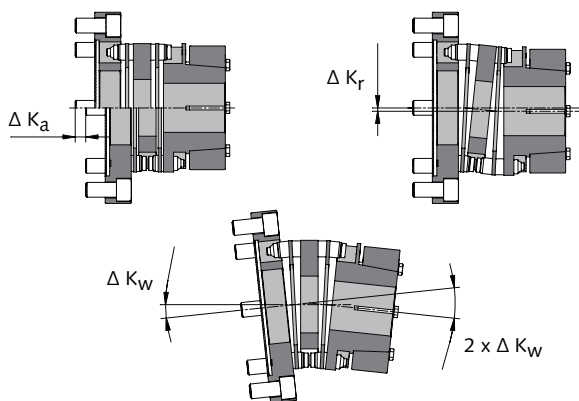

The multi-disk coupling uses a two disc assembly to compensate for angular, axial, and radial shaft offsets. If multiple offsets occur simultaneously, they influence one another. The permissible values for displacement are therefore depending on each other. The sum of the actual displacements – in percent of the maximum values – may not exceed 100 %.

Possible Adaptations



Adapter Flange + Coupling Type 2300A... Variant S: Tension Ring Hub





Adapter Flange + Coupling Type 2300A... Variant H: Half-Shell Hub



Adapter Flange + Coupling Type 2300A... Variant F: Flange

Couplings for Rotating Torque Sensors

Couplings			
Type	2301A...	2302A...	2303A...
Name	Metal Bellows Coupling with Clamping Hubs	Torsion Proof Miniature Coupling, Single-Flexible with Clamping Hubs	Torsion Proof Miniature Coupling, Double-Flexible with Clamping Hubs
For Measuring Ranges	5 ... 1 500 N·m	to max. 36 N·m	to max. 36 N·m
For Sensor	Torque Sensor Type 4520A..., Type 4502A..., and Type 4503A...	Torque Sensor Type 4501A..., Type 4502A..., Type 4503A... and Type 4520A...	Torque Sensor Type 4501A..., Type 4502A..., Type 4503A... and Type 4520A...

Possible Adaptations

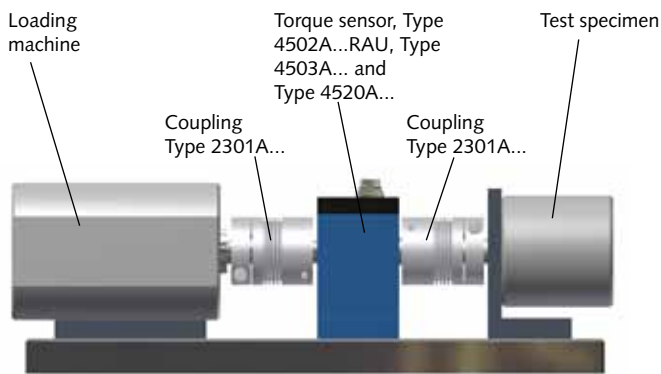

Application

Two double-flexible bellows couplings provide compensation, when torque sensors with fixed housing are required. Compensation of misalignment is always needed to avoid measurement error and damage to the sensor. Installation of sensors with fixed housing or mounting support requires double-flexible couplings on both sides of the sensor. Each coupling is mounted via clamping hubs on both sides. The frictional clamped connection guarantees absolutely backlash-free installation.

Data sheet 2301A_000-673

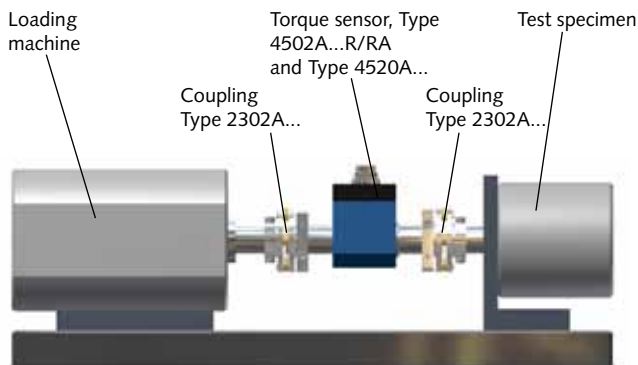

Application

Two single-flexible couplings provide compensation, when torque sensors must be installed self-supporting into a shaft assembly. Compensation of misalignment is always needed to avoid measurement error and damage to the sensor.

Data sheet 2302A_000-671

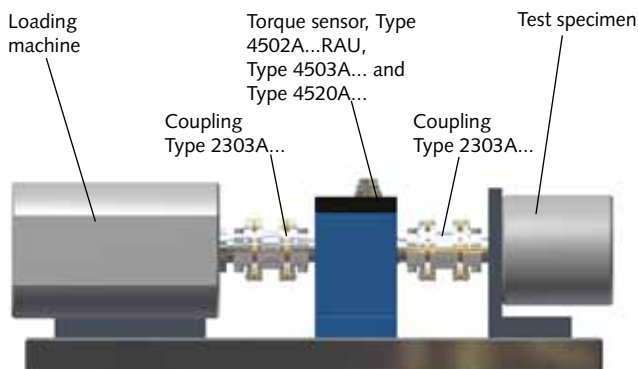

Application

Two double-flexible couplings provide compensation, when torque sensors with fixed housing must be installed. Compensation of misalignment is always needed to avoid measurement error and damage to the sensor. Installation of sensors with fixed housing or mounting support requires double-flexible couplings on both sides of the sensor. Each coupling is mounted via clamping hubs on both halves.

Data sheet 2303A_000-672

Couplings for Torque Measuring Flanges

Torsion Proof Multi-Disk Coupling for Torque Measurement Flange Type 4504B...



Coupling,
Type 2300A... variant S
with tension ring hub



Coupling,
Type 2300A... variant F
with flange



Coupling,
Type 2300A... variant H
with half-shell hub



Coupling,
Type 2300A... variant A
with tension ring hub

General technical data			Type 2300A10...	Type 2300A25...	Type 2300A40...
Coupling for sensor Type			4504...50/100...	4504...200...	4504...500...
Rated torque	T_{KN}	N·m	100	420	650
Peak transient torque	T_{Kmax}	N·m	150	630	975
Coupling outside diameter	D_{aK}	mm	69	89	104
Torsion resistance (per assembly)	C_T	$10^3 \cdot N \cdot m / rad$	60	290	320
Overall torsion resistance	$C_{T overall}$	$10^3 \cdot N \cdot m / rad$	30	145	160

General technical data			Type 2300A100...	Type 2300A300...	Type 2300A500...
Coupling for sensor Type			4504...1K...	4504...2K...	4504...3K...
Rated torque	T_{KN}	N·m	1 600	3 500	5 800
Peak transient torque	T_{Kmax}	N·m	2 400	5 250	8 700
Coupling outside diameter	D_{aK}	mm	143	167	198
Torsion resistance (per assembly)	C_T	$10^3 \cdot N \cdot m / rad$	1 900	3 480	11 900
Overall torsion resistance	$C_{T overall}$	$10^3 \cdot N \cdot m / rad$	950	1 740	5 950

General technical data			Type 2300A850...
Coupling for sensor Type			4504...5K...
Rated torque	T_{KN}	N·m	9 500
Peak transient torque	T_{Kmax}	N·m	14 250
Coupling outside diameter	D_{aK}	mm	234
Torsion resistance (per assembly)	C_T	$10^3 \cdot N \cdot m / rad$	20 600
Overall torsion resistance	$C_{T overall}$	$10^3 \cdot N \cdot m / rad$	10 300

Characteristics

Torsion proof multi-disk coupling for effective, space-saving connection of torque sensor Type 4504A... into the shafting.

Applications

The multi-disk coupling is used to compensate for axial, radial and angular misalignment with a torque sensor. This is always essential to avoid measurement errors and damage to the sensor. The different variants allow easy integrating of the sensor into virtually any application.

Included accessories

Screws for assembly with sensor Type 4504B...

Data sheet 2300A_000-667

Accessories

Couplings for Torque Sensors

Metal Bellows Coupling with Clamping Hubs

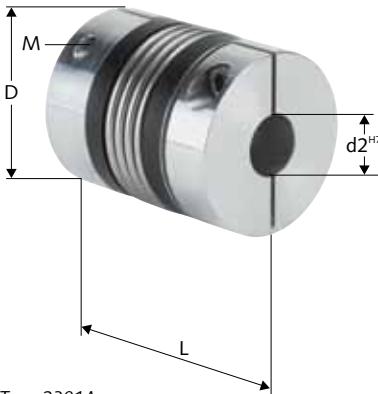

Technical data			Type 2301A15	Type 2301A30	Type 2301A60
Rated torque	T_{KN}	N·m	15	30	60
Torsion resistance	C_{Tdyn}	$10^3 \cdot N \cdot m / rad$	20	39	76
Moment of inertia	J	$10^{-3} \cdot kg \cdot m^2$	0,06	0,12	0,32
L		mm	59	69	83
$d2^{H7}$ (min ... max)		mm	8 ... 28	10 ... 30	12 ... 35
D		mm	49	55	66
M			M5	M6	M8
Mass		kg	0,15	0,3	0,4

Technical data			Type 2301A80	Type 2301A150	Type 2301A200
Rated torque	T_{KN}	N·m	80	150	200
Torsion resistance	C_{Tdyn}	$10^3 \cdot N \cdot m / rad$	129	175	191
Moment of inertia	J	$10^{-3} \cdot kg \cdot m^2$	0,8	1,9	3,2
L		mm	94	95	105
$d2^{H7}$ (min ... max)		mm	14 ... 42	19 ... 42	22 ... 45
D		mm	81	82	90
M			M10	M10	M12
Mass		kg	0,8	1,7	2,5

Technical data			Type 2301A300	Type 2301A500	Type 2301A800
Rated torque	T_{KN}	N·m	300	500	800
Torsion resistance	C_{Tdyn}	$10^3 \cdot N \cdot m / rad$	450	510	780
Moment of inertia	J	$10^{-3} \cdot kg \cdot m^2$	7,6	14,3	16,2
L		mm	111	133	140
$d2^{H7}$ (min ... max)		mm	24 ... 60	35 ... 60	40 ... 75
D		mm	110	124	134
M			M12	M16	2xM16
Mass		kg	4	7,5	7

Technical data			Type 2301A1500
Rated torque	T_{KN}	N·m	1 500
Torsion resistance	C_{Tdyn}	$10^3 \cdot N \cdot m / rad$	1 304
Moment of inertia	J	$10^{-3} \cdot kg \cdot m^2$	43
L		mm	166
$d2^{H7}$ (min ... max)		mm	50 ... 80
D		mm	157
M			2 x M20
Mass		kg	12

General technical data			
Peak transient torque	T_{Kmax}	N·m	brief overload of up to 1,5 times value permissible
Max. speed	n_{max}	1/min	<10 000 / >10 000 on request
Operating temp. range		°C	-30 ... 120

Characteristics

Torsion proof stainless steel bellows for coupling both sides of a torque sensor with fixed housing or mounting support into shafting. Low moment of inertia; requires little space; wear and maintenance free.

Applications

The coupling compensates for misalignment where fixed mounting of the torque sensor in shafting is required. This is always essential to avoid measurement errors and damage to the sensor. A double-flexible coupling must be used with clamping hubs on both sides of sensors mounted with rigid housing

or mounting support. The clamped connection relying on friction allows completely backlash-free installation.

Accessories

None

Data sheet 2301A_000-673

Couplings for Torque Sensors

Torsion Proof Miniature Coupling, Single-Flexible with Clamping Hubs

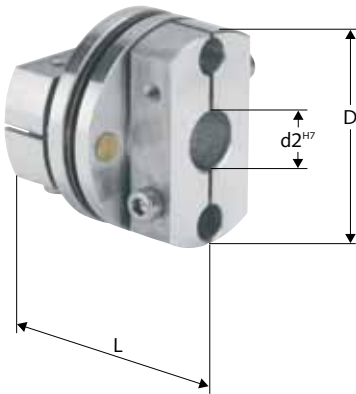

Type 2302A...

Technical data			Type 2302A25	Type 2302A37	Type 2302A50
Rated torque	T_{KN}	N·m	0,39	1,56	6,17
Maximaldrehmoment	T_{Kmax}	N·m	0,54	2,19	8,64
Torsion resistance	C_{Tdyn}	$10^6 \cdot N \cdot m / rad$	3,89	25,986	39,768
Moment of inertia	J	$10^{-6} \cdot kg \cdot m^2$	1,83	11,1	28,56
Max. speed	n_{max}	1/min	64 000	44 000	36 000
L		mm	20,2	29,1	30,4
$d2^{H7}$ (min ... max)		mm	3 ... 10	4 ... 14	6 ... 18
D		mm	25,4	35,8	44,5
Mass		g	22	62	100

Technical data			Type 2302A62	Type 2302A75
Rated torque	T_{KN}	N·m	24,7	36,2
Maximaldrehmoment	T_{Kmax}	N·m	34,6	50,7
Torsion resistance	C_{Tdyn}	$10^6 \cdot N \cdot m / rad$	103,572	161,76
Moment of inertia	J	$10^{-6} \cdot kg \cdot m^2$	78,61	159,4
Max. speed	n_{max}	1/min	28 000	24 000
L		mm	36,6	41
$d2^{H7}$ (min ... max)		mm	10 ... 24	12 ... 28
D		mm	57,4	64
Mass		g	195	278

Characteristics

Torsion proof miniature coupling for self-supporting mounting of torque sensors without fixed housing in shafting; high speed range; light, low moment of inertia, high torsion resistance, wear and maintenance free; corrosion free, antimagnetic.

Applications

This coupling compensates for misalignment where self-supporting mounting of torque sensors in shafting is required. This is always essential to avoid measurement errors and damage to the sensor.

Accessories

None

Data sheet 2302A_000-671

Accessories

Couplings for Torque Sensors

Torsion Proof Miniature Coupling, Double-flexible with Clamping Hub

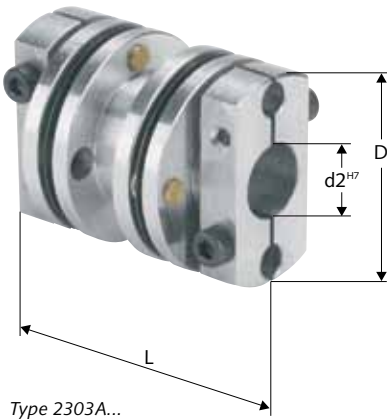

Technical data			Type 2303A25	Type 2303A37	Type 2303A50
Rated torque	T_{KN}	N·m	0,39	1,56	6,17
Peak transient torque	T_{Kmax}	N·m	0,54	2,19	8,64
Torsion resistance	C_{Tdyn}	$10^3 \cdot N \cdot m / rad$	1,945	12,993	19,884
Moment of inertia	J	$10^{-6} \cdot kg \cdot m^2$	2,33	14,01	37,99
Max. speed	n_{max}	1/min	64 000	44 000	36 000
L		mm	34	48	54
$d2^{H7}$ (min ... max)		mm	3 ... 10	4 ... 14	6 ... 18
D		mm	25,4	35,8	44,5
Mass		g	28	77	133

Technical data			Type 2303A62	Type 2303A75
Rated torque	T_{KN}	N·m	24,7	36,2
Peak transient torque	T_{Kmax}	N·m	34,6	50,7
Torsion resistance	C_{Tdyn}	$10^3 \cdot N \cdot m / rad$	51,786	80,88
Moment of inertia	J	$10^{-6} \cdot kg \cdot m^2$	104,28	203,55
Max. speed	n_{max}	1/min	28 000	24 000
L		mm	66	71
$d2^{H7}$ (min ... max)		mm	10 ... 24	12 ... 28
D		mm	57,4	64
Mass		g	260	355

Characteristics

Torsion proof miniature coupling for connecting both sides of torque sensors with fixed housing or mounting support into shafting; high speed range; light, low moment of inertia, high torsion resistance, wear and maintenance free; corrosion free, antimagnetic.

Applications

This coupling compensates for misalignment where fixed mounting of torque sensor in the shafting is required. This is always essential to avoid measurement errors and damage to the sensor. A double-flexible coupling with clamping hubs has to be provided on both sides of sensors with fixed housing or mounting support.









Accessories

None

Data sheet 2303A_000-672

Connecting Cables for Rotating Torque Sensors

Connecting Cables for Sensors

	Technical data	Type KSM071860-5 (for Type 4501A...)	
	Connector	6 pin neg. – 6 pin pos.	
	Length	m	5
	Diameter	mm	6
	Technical data	Type KSM103820-5 (for Type 4501A...)	
	Connector	6 pin neg. – open	
	Length	m	5
	Diameter	mm	6
	Technical data	Type KSM183150-5 (only for 4501A..., QA and HA)	
	Connector	12 pin neg. – open	
	Length	m	5
	Diameter	mm	6
	Technical data	Type KSM124970-5 (for Type 4502A..., 4503A..., 4504..., 4510..., 4541A...)	
	Connector	12 pin neg. – open	
	Length	m	5
	Diameter	mm	6
	Technical data	Type KSM219710-5 (for Type 4503A..., 4504..., 4510..., 4541A...)	
	Connector	7 pin neg. – open	
	Length	m	5
	Diameter	mm	6
	Technical data	Type KSM385370-5 (for Type 4541A...)	
	Connector	14 pin neg. – open	
	Length	m	5
	Diameter	mm	6
	Technical data	Type KSM186420-2,5 (for Type 4503, 4504..., 4541A...)	
	Connector	12 pin neg. – D-Sub pos.	
	Length	m	2,5
	Diameter	mm	6
	Technical data	Types KSM000822, KSM000517, KSM013136, KSM038290, KSM000703	
	Connector	6-, 7-, 8-, 9- (D-Sub), 12-, 14 pin neg.	
	Deg. of protection to IEC/EN 60529	IP40	













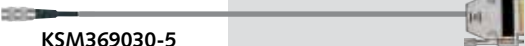



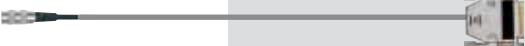



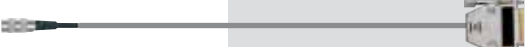

Connector for Torque Sensors, Force Sensors and Force Measuring Flanges

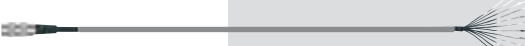

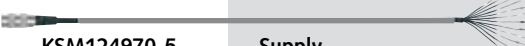



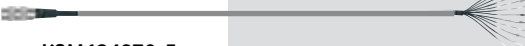

Female Cable Connector for Sensors Types 4501A... to 4504..., 4520A..., 4510B... and 4541A..., 4576A... to 4579A...

Technical data	Types KSM000822, KSM000517, KSM013136, KSM038290, KSM000703	
Connector	6-, 7-, 8-, 9- (D-Sub), 12-, 14 pin neg.	
Deg. of protection to IEC/EN 60529	IP40	

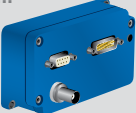
Other connectors/cable boxes, see **data sheet** 000-615

Examples Typical Measuring Chains

M Measuring Chain for Automated Testing of Gearboxes				
	Measuring	Connecting	Amplifying	Analyzing
Cyclical function test of assembly power tools in quality assurance	 4501A...	 KSM07186-5  KSM369030-5	4701A... Signal e.g. 10 V analog 	External test control unit  maXYmos BL 5867A...
Routine test of torque in production	 4520A... 4502A...	 KSM185380-2,5		 CoMo Torque 4700B...
Measurement of torque and evaluation with ControlMonitor	 4503A...	 KSM186420-2,5		 CoMo Torque 4700B...
Testing of characteristic torques and evaluation with test stand control system	 4503A...	 KSM124970-5		 Analog PLC
Torque measurement in laboratory applications, measurement value acquisition with PC software SensorTool	 4510B... 4504B... 4550A... 4541A...	 KSM124970-5  KSM214680-5	Supply  Signal/Control	External power supply  PC with SensorTool 4706A
Testing of characteristic torques and evaluation with test stand control system	 4550A.../4541A...	 KSM124970-5		 RS-232C PLC

M Measuring Chains for Spring-Loaded Switches				
	Measuring	Connecting	Amplifying	Analyzing
Measuring of low switching force, evaluated by machine controller	 9339A 9329A ... 9389A	 1631C...	5073A1... 5030A... 	
Monitoring of switching force curve, evaluated using XY-monitor maXYmos TL	 9339A 9329A ... 9389A	 1631C...		 5877A...

Standard equipment

Alternative

Torque Measurement Technology

Whether torsion rod or fast running drive shaft – the knowledge of the appearing torques gives information about static and dynamic load, movement properties of gearboxes and in combination with rotation speed measurements about the capability of a power train.

Torque measurements on rotating shafts are particularly done with strain gage technology (DMS). Highest precision, highest possible stiffness and high temperature stability are essential requirements.

Transmission of supply and measuring signal of modern torque measuring shafts is

usually working contactless. If, as e.g. like Type 4504B... and Type 4510B... there is no bearing of the measuring shaft, a high precision and completely wear-out free measuring device arises.

In case of applications for measurement of reaction moments, which request high measuring ranges, extremely overload protection and high resolution, piezoelectric sensors prove themselves. Even in case of high mechanical loads they will measure lowest torque deviations.

Kistler product line offers with DMS and piezoelectric sensors solutions for all measurement tasks.

Strain Gage or Piezoelectric? Solutions for any requirements!

Strain gage sensors for:

- + measurements on rotating shafts
- + maximum precision
- + dynamic and static continuous measurement

Piezoelectric reaction torque sensor for

- + extreme overload capacity
- + high resolution of signal at smallest range of rated torque
- + wide frequency range

Basic Calibration Terms

Sensitivity

Value of the change in output signal divided by the corresponding change in the input variable: $\Delta Q/\Delta I_{Ref}$ for piezoelectric sensors or $\Delta U/\Delta I_{Ref}$ in the case of strain gage sensors.

FSO

Full Scale Output or full range signal. The difference between the output signal at zero and at the end of the measuring range.

Hysteresis

Maximum difference, H_{max} , between rising load characteristic and falling load characteristic.

Calibration

Calibration is the use of a defined method under specified conditions to determine the relationship between a known input variable and a measured output variable. The calibration standard is the reference value. For example, the calibration of scales involves placing a defined and calibrated test weight (calibration standard) on the scales to reveal deviations in the weight reading.

Calibration curve

This curve shows the output variable of a sensor as a function of the input variable.

Calibration standard

The calibration standard, which is traceable to national or international standards, is the reference value used for calibrating sensors or measuring instruments.

Calibration certificate

The calibration certificate documents all values measured during calibration and the calibration conditions.

Characteristic value

Output signal of the strain gage sensor at rated load, reduced by the zero signal after mounting.

Linearity

In practical application there is not an exactly linear (or constant) relationship between the measurand and the output variable of the sensor. The linearity L_{max} of a sensor corresponds to the maximum deviation of the ideal from the actual output signal curve in relation to the measurand within a certain measuring range.

It is expressed as a percentage of the limit of the full measuring range (% FSO).

Best straight line

Determination of a linear function passing through the origin to form the calibration curve, with two parallel straight lines with the same gradient and shortest distance apart enveloping all of the calibration values.

Least squares function

Determination of a linear function to form the calibration curve that minimizes the sum of the squares of the errors (differences between calibration curve and linear function).

Calibration

Calibration Methods

During calibration, sensors are subjected to known quantities of a physical measurand such as force or torque and the corresponding values of the output variable recorded. The magnitude of this load is accurately known, as it is measured with a traceably calibrated "factory standard" at the same time. Depending on the method, sensors are calibrated either across the entire measuring range or in a partial range:

- at a single point,
- stepwise at several different points or
- continuously.

Step-by-step calibration involves the application of a defined load with or without unloading between successive increases or decreases, depending on the calibration method used. The process is halted after each increment until the measurement stabilizes.

DKD (German calibration service), successor organization Dakks (accreditation body for the Federal Republic of Germany) accredited calibration device for torque calibrations up to 5 000 N·m

Calibration

The torque reference standard calibration machine marks the state of the art in calibration of torque sensors.

It has been developed in cooperation with the torque laboratory of the Physikalisch-Technische Bundesanstalt, Braunschweig, the German national metrology institute.

The torque is created by sliding weights, that are automatically arranged and positioned on a lever arm.

Next to the standard static calibration, this design makes possible quasi-continuous calibration of torque sensors over the whole measuring range.

The computer controlled calibration method is incorporated in Kistler's DIN ISO 9001 process and offers the users of torque sensors a complete documentation of calibration, which can be embedded seamlessly into the DIN ISO of the customer.

The calibration laboratory is accredited since 2004, so that works calibration certificates and DKD certificates can be issued.

At a Glance

Kistler offers a comprehensive calibration service:

- Calibration of test equipment
- Accredited calibration laboratory (SCS 049 DKD-37701)
- Extensive functional testing
- Range of different calibration documents



Basics of Piezoelectric Sensors

Kistler supplies piezoelectric, piezoresistive, capacitive and strain gage sensors. Piezoelectric designs are particularly suitable for measurement imposing extreme requirements in terms of geometry, temperature range and dynamics. Kistler therefore relies mainly on the piezoelectric principle for measuring dynamic forces in assembly and testing.

The Piezoelectric Effekt in Detail

The term piezoelectricity refers to a linear electromechanical interaction between the mechanical and electrical state of anisotropic crystals that is those without a center of symmetry with lattice structure. These crystals have one or more polar axes along which the piezoelectric effect occurs as a result of an external force deforming the crystal lattice and pushing its positive and negative elements against one another. This produces an electric dipole moment.

Depending on the orientation of the axes with respect to the applied force, three different effects can be discerned:

- Longitudinal
- Shear
- Transverse

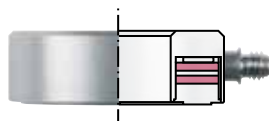

Torque sensor



Reaction torque sensor

Advantages at a Glance

Feature of piezoelectric sensors:

- Withstands temperatures up to 300 °C
- Very high rigidity
- High linearity
- Negligible hysteresis
- Extreme high overload protection
- High frequency range



Basics of Piezoelectric Measurement Technology

Shear effect

Similarly to the longitudinal effect, the piezoelectric sensitivity involved in the shear effect is independent of the size and shape of the piezoelectric element. The charge is also developed on the piezo element's loaded surfaces. In the case of a load in the x-direction applied to n elements connected mechanically in series and electrically in parallel, the charge is:

$$Q_x = 2 \cdot d_{11} \cdot F_x \cdot n$$

Shear-sensitive piezo elements are used for sensors measuring shear forces, torque and strain. They are suitable for manufacturing sensors whose excellent performance is unaffected by temperature changes, as the changes in the stresses in the sensor structure caused by changes in the temperature act in a direction perpendicular to the sensitive shear axis.

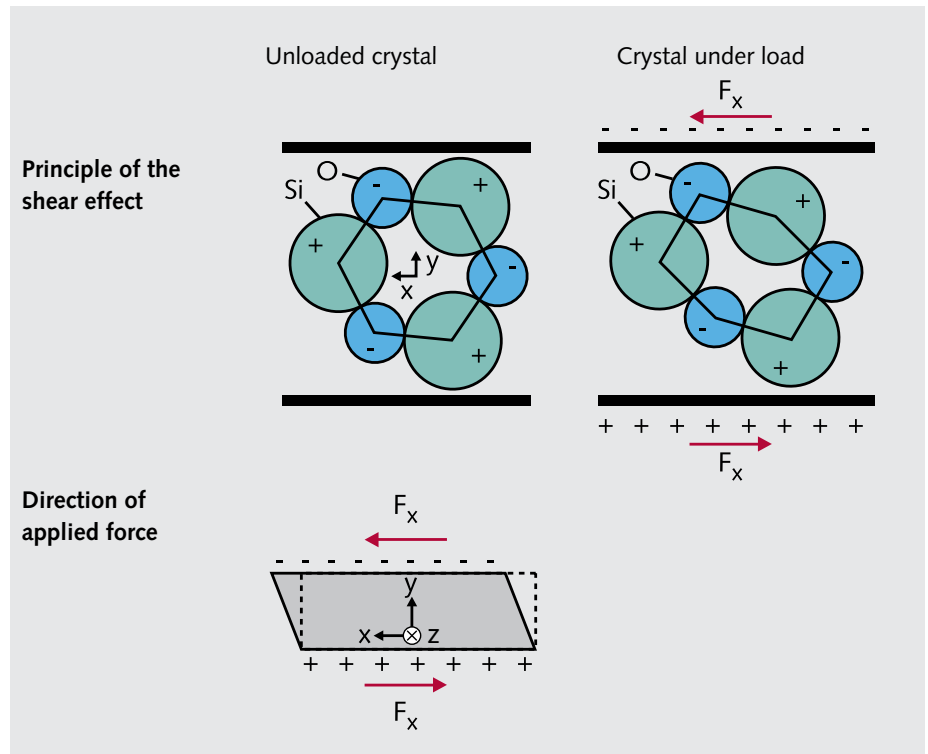

d_{11} : piezoelectric coefficient
(-2,3 pC/N for quartz crystals)

F_x : force in x-direction
 n : number of crystal disks

Force Sensors, Strain Sensors and Torque Sensors

Quartz disks with piezoelectric properties can be stacked in sensors to allow the measurement of one or more force components or a torque vector. Kistler offers the following piezoelectric sensors for application in assembly and product testing:

- Single-component force sensors
- Multicomponent force sensors
- Strain sensors
- Torque sensors

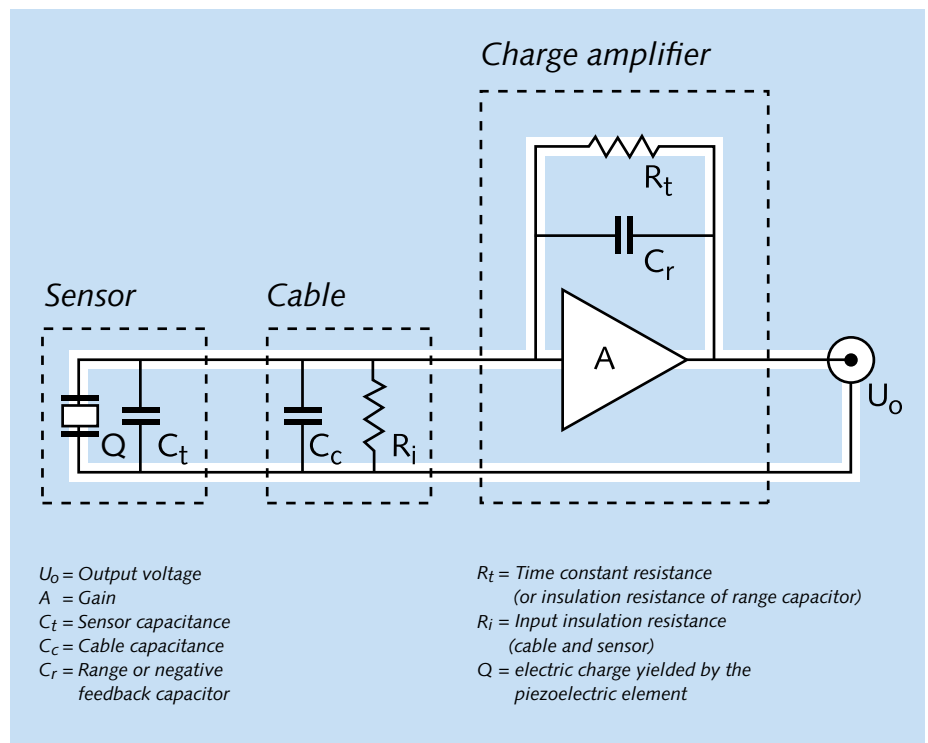

Block diagram of a measuring chain

Basics of Strain Gage Sensors

Wheatstone bridge

A Wheatstone bridge is generally used to convert the very small changes in resistance caused by the deformation of a force detector in the strain gages into a voltage signal capable of evaluation.

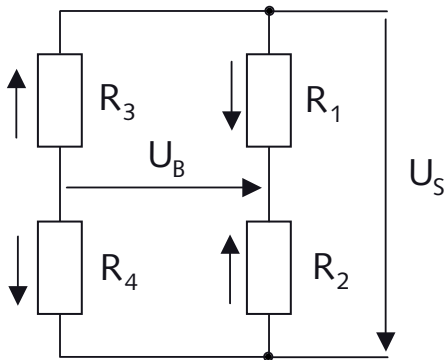

Die Wheatstonesche Messbrücke
 $R_1 \dots R_4$: Widerstände bzw. DMS
 U_S : Speisespannung
 U_B : Ausgangsspannung
 E_B : Brückenempfindlichkeit

This bridge consists of four resistors or strain gages. It is supplied with voltage U_S . The output voltage U_B is taken off the middle of the bridge. The sensitivity of the bridge E_B gives the relationship between output voltage with gage factor (k) and strain ε . Depending on the design, different numbers of resistors can take the form of strain gages. In the case of a full bridge all four resistors are strain gages and the value of their resistance is changed by an external factor such as torque or force.

$$E_B = \frac{U_B}{U_S} = k \cdot \varepsilon$$

The arrangement of the strain gages on the force detector shown in the diagram results in two gages being compressed (resistance of R_1 and R_4 reduces) and two stretched (resistance of R_3 and R_2 increases). The type of force detector and the load do not always allow strain gages to be stretched and compressed with a single loading direction. In this case either two (half bridge), or even three resistors (quarter bridge) must be replaced with fixed resistors. In this case the sensitivity of the bridge is correspondingly lower.

As the temperature dependency of the bridge is a very important quality characteristic, in quarter and half bridges the fixed resistors generally also take the form of strain gages, which are geometrically very close to one another and unaltered by the load. In the event of a change in temperature the resistance values of the strain gages (for example, of R_1 and R_3) increase by the same amount, so the output voltage does not change.

For strain gage sensors full bridges are used almost exclusively. The bridge is generally supplemented with other resistors to compensate for various factors.

Advantages of Strain Gage Sensors

- + Allow tensile and compression measurements without having to preload measuring elements.
- + Static measurements over long period of time possible.
- + Simple static calibration with weight loading.

Measuring chain with strain gages

The voltages produced by the bridge are in the range of a few mV. The leads for the unamplified analog signals are kept as short as possible to minimize the effect of any electromagnetic fields. A differential amplifier generally amplifies and then digitizes the voltage. Such amplifiers have a very high input resistance and high common-mode rejection.

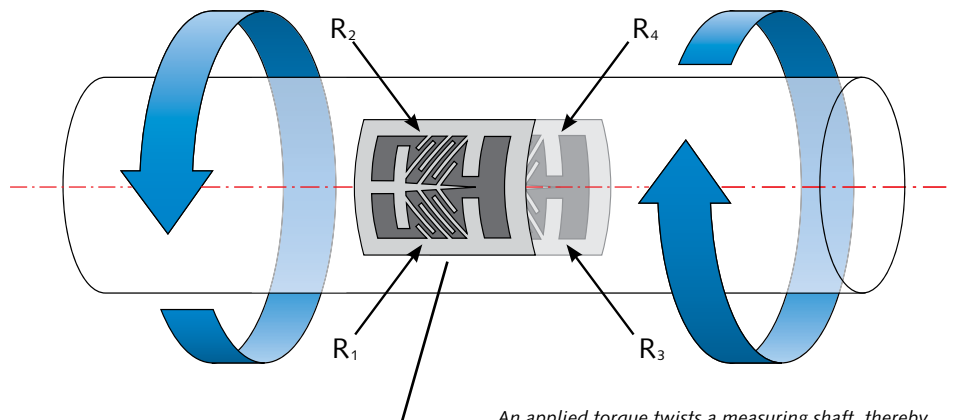

An applied torque twists a measuring shaft, thereby affecting the resistors of the full bridge R_1 to R_4 and producing a voltage proportional to the torque

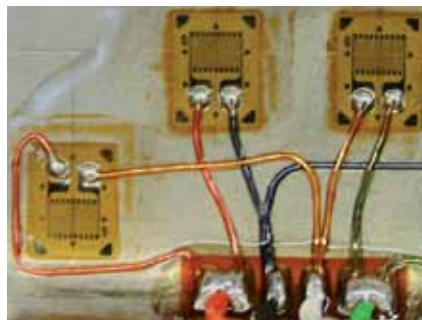

Strain gages soldered onto a structure

Assembly Rotating Strain Gage Sensors

Rotating torque sensors and Measuring Flanges

Rotating torque sensors and measuring flanges have two pairs of coils. The first pair transfers the power to supply the rotor, and data from stator to rotor. The digital data from the rotor is transferred to the stator by means of the other pair of coils. The electronics with the differential amplifier and the analog-to-digital converter are mounted on the rotor.

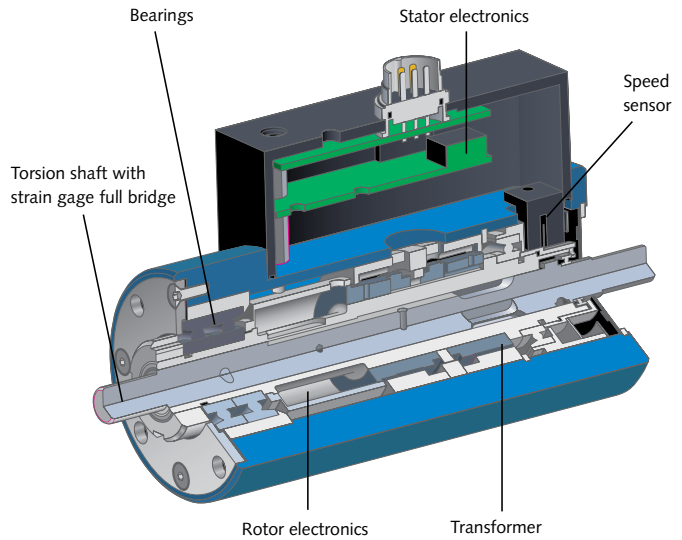

Assembly of torque sensor Type 4503A...

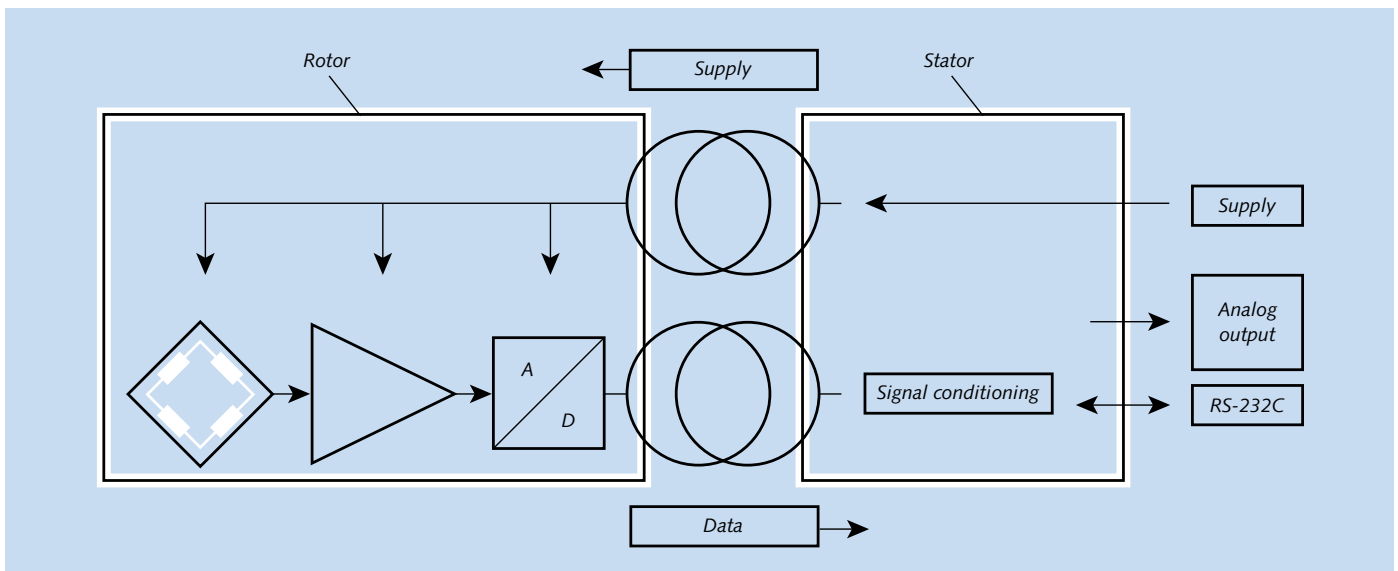

Schematic of a torque sensor for rotating shafts



Type 4541A... Type 4550A...
KiTorq Stator KiTorq Rotor
Torque measuring flange
KiTorq System



Type 4503A...
Torque sensor

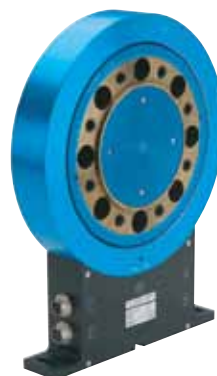

Type 4504...
Torque measuring flange



Type 4501A... / Type 4502A...
Torque sensor

Technical Literature

Special Reprints and Application Brochures

The Basics of Piezoelectric Measuring Technology

Investigation of Piezoelectric Force Measuring Devices in Force Calibration and Force Standard Machines 920-232

Dynamic Properties and Investigation of Piezoelectric Force Measuring Devices 920-233

Guide to the Measurement of Force 20.193

Monitoring of Manufacturing, Assembly and Testing Processes

Monitored Press-Fitting and Joining Processes 920-223

Process Monitoring – for Better Quality and Increased Production 920-224

Reliable Connection through Monitoring of Joining Forces 920-351

From Sensor to Transmitter - Robust Industrial Sensors through Integration of Electronics 920-361

General Force Measurement

Force and Moment Measurements in Aerodynamics and Aeroelasticity Using Piezoelectric Transducers 920-363

Monitoring of Resistance Welding Processes

Electrode Force Measurement – Spot Welds that Stay 300-322

Force Measurement in Resistance Welding 920-332

Force Monitoring Optimizes Resistance Welding and Related Joining Processes 920-345

Test Stand Systems

Test Stand Systems for Electric Motors and Gearboxes in Laboratory, Manufacturing and Quality Assurance 300-604

NC Joining Module

Flexible Solutions for Your Application 300-614

The references are Kistler Group document numbers. Most of these documents are available for downloading from www.kistler.com.

Product Overview by Type Numbers

Type	Page	Type	Page	Type	Page	Type	Page	Type	Page	Type	Page
2300A...S...	26	4501A...	110	4700B...	22	5073A5...	20	9378C	94	KSM038290	30
2300A...F...	26	4502A...	110	4701A...	21			9389A	107	KSM071860-5	30
2300A...H...	26	4503A...	112	4706A	23					KSM103820-5	30
2300A...A..	26	4504B...	113							KSM124970-5	30
2301A...	27	4510B...	114	5073A1...	20			KSM000517	30	KSM183150-5	30
2302A...	28	4520A...	111	5073A2...	20	9275	12	KSM000703	30	KSM186420-5	30
2303A...	29	4541A...	115	5073A3...	20	9277A25	13	KSM000822	30	KSM219710-5	30
		4550A...	115	5073A4....	20	9345B	12	KSM013136	30	KSM385370-5	30

Windows® and Windows CE® are registered trademarks of Microsoft Corporation.

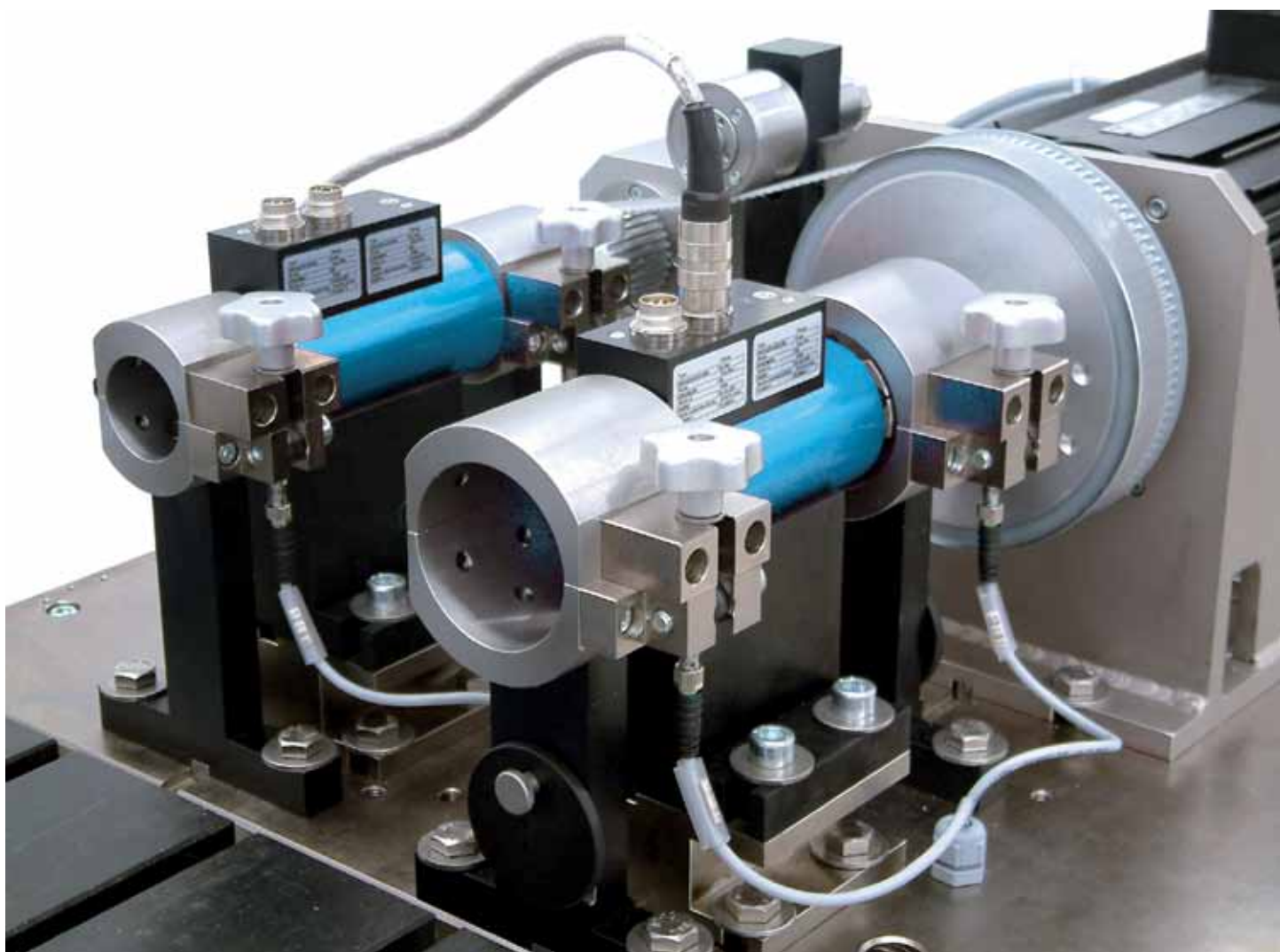

Motor test stand with torque sensors Type 4503A...

Kistler Worldwide

Europe

Austria

Kistler GmbH
1230 Wien
Tel. +43 1 867 48 67 0
sales.at@kistler.com

Czech Republic/Hungary/ Poland/Slovakia

Kistler, s.r.o.
140 00 Praha 4
Tel. +420 296 374 878
sales.cz@kistler.com

Denmark

Kistler Nordic DK
4681 Herfølge
Tel. +45 70 20 85 66
info.dk@kistler.com

Finland

Kistler Nordic AB
00210 Helsinki
Tel. +358 9 612 15 66
info.fi@kistler.com

France

Kistler France
91953 Les Ulis cedex
Tel. +33 1 69 18 81 81
info.fr@kistler.com

Germany

Kistler Instrumente GmbH
73760 Ostfildern
Tel. +49 711 34 07 0
info.de@kistler.com

Italy

Kistler Italia s.r.l.
20149 Milano
Tel. +39 02 481 27 51
sales.it@kistler.com

Netherlands

Kistler B.V. Nederland
2811 DT Reeuwijk
Tel. +31 182 304 444
sales.nl@kistler.com

Spain

Kistler Ibérica S.L, Unipersonal
Barcelona
Tel. +34 93 860 33 24
info.es@kistler.com

Sweden/Norway

Kistler Nordic AB
431 53 Mölndal
Tel. +46 31 871 566
info.se@kistler.com

Switzerland/Liechtenstein

Kistler Instrumente AG
8408 Winterthur
Tel. +41 52 224 12 32
sales.ch@kistler.com

United Kingdom

Kistler Instruments Ltd.
Hook, Hampshire RG27 9GR
Tel. +44 1256 74 15 50
sales.uk@kistler.com

Asia

China, People's Republic of

Kistler China Ltd.
Hong Kong
Tel. +852 25 915 930
sales.cn@kistler.com

India

Kistler Instruments (India) Pvt .Ltd.
Faridabad - 121 007, Haryana/India
Tel. +91 129 4113 555
sales.in@kistler.com

Japan

Kistler Japan Co., Ltd.
Tokyo 108-0022
Tel. +81 3 3769 9501
sales.jp@kistler.com

Korea, Republic of

Kistler Korea Co., Ltd.
Anyang-City, Gyeonggi-Do 430-731
Tel. +82 31 465 6013
sales.kr@kistler.com

Singapore

Kistler Instruments (Pte) Ltd.
Singapore 573968
Tel. +65 6570 5377
sales.sg@kistler.com

Taiwan

Kistler Instrumente AG, Taiwan Branch
Taipei 114
Tel. +886 2 7721 2121
sales.tw@kistler.com

Thailand

Kistler Instrument (Thailand) Co., Ltd.
Bangkok 10120
Tel. +66 2678 6779-80
sales.thai@kistler.com

America

Brasil

Kistler Brasil Ltda
CEP 040 28-001, Sao Paulo - SP Brasil
Tel. +55 11 50520308
sales.br@kistler.com

Mexico

Kistler Instruments S de RL de CV.
Apodaca, NL. 66629
Tel. +52 81 8881 3214
sales.mx@kistler.com

USA/Canada

Kistler Instrument Corp.
Amherst, NY 14228-2171
Tel. +1 716 691 5100
sales.us@kistler.com

Australia

Australia

Kistler Instruments Australia Pty Ltd
Wheelers Hill, Victoria 3150
Tel. +61 3 9560 5055
sales.au@kistler.com

Other Countries

Kistler Instrumente AG

Export Sales
Eulachstrasse 22, 8408 Winterthur
Switzerland
Tel. +41 52 224 11 11
sales.export@kistler.com

Headquarters

Switzerland

Kistler Group
Eulachstrasse 22, 8408 Winterthur
Tel. +41 52 224 11 11
Fax +41 52 224 14 14
info@kistler.com

www.kistler.com

KISTLER

measure. analyze. innovate.