

KISTLER

measure. analyze. innovate.

maXYmos BL maXYmos TL

**XY Monitors for
Process Monitoring
with 100 % Quality
in Manufacturing,
Assembly and
Product Testing**



maXYmos XY Monitors for 100 % Quality in Assembly and Product Testing

The maXYmos XY monitors make it possible to check and evaluate the quality of a product or production step on the basis of a curve. The user can apply evaluation objects in order to adapt the curve evaluation to the individual monitoring task. Based on this specification, the maXYmos can check each workpiece and decide whether the part is good or bad.

By performing such monitoring earlier within the manufacturing chain, more rejects are avoided. Consistent quality assurance integrated into the processes ensures high product quality. Moreover, faulty parts are sorted out extremely early and subsequent system components are supplied only with good parts. This helps to maximize production capacity and system utilization while minimizing production costs.

The maXYmos XY monitors make it possible to check and evaluate the quality of a product or production step on the basis of a curve. The monitors record the interrelation of all of the measurands that can be measured, for example, with force or torque sensors on the Y-channel and with displacement or rotation angle sensors on the X-channel. Quality-relevant sections of the measurement curves recorded by means of measurement functions such as $Y=f(X)$, $Y=f(t)$, $Y=f(X,t)$ and $X=f(t)$ are analyzed with the aid of evaluation objects. This involves the maXYmos checking whether the curves pass through the evaluation objects as predefined. If they

do, it generates an "OK", otherwise a "not OK" (NOK) result.

The maXYmos monitors from Kistler check and evaluate XY curves of two measurands that have to stand in a certain relation to each other.

Such curves arise in applications such as

- Press fitting ball bearings
- Pivoting and adjusting rake of backrests
- Riveting and caulking casing parts
- Tactile manipulation of rotary switches, etc.
- Testing springs
- Measuring of haptic behavior as can occur during switch tests

maXYmos Family: XY Monitors for Good/Bad Evaluation of Curves

The maXYmos product family currently consists of two models: The maXYmos BL (Basic Level) and the maXYmos TL (Top Level). The two models share a highly logical, systematic and easy to understand menu concept that ensures intuitive op-

eration. Users will quickly understand how to use both models: Anyone already familiar with one maXYmos model can quickly learn to use the other model to obtain dependable results. This is a major advantage in cases where both monitor types are installed on one and the same machine.

The maXYmos XY monitors have a universal case concept: With both models, a minimum of manipulation is required to convert from the panel version with flush mounting of the front to the desktop or wall-mounting version.

The maXYmos BL and maXYmos TL are also fully compatible in terms of all electrical and control aspects: Their identical signal and data formats combined with identical interfaces and connectors ensure smooth handshaking with no problems.

📍 XY Monitoring at a Glance

- In-process monitoring of joining and assembly processes
- Early detection of quality variations in the production process
- Transparency in production process enables fast feedback
- Traceable process results
- Economization of test routines

➕ Benefits of the maXYmos Family

- Easy integration into existing systems and processes
- Intuitive and consistent operating concept
- Powerful evaluation objects
- Extensive diagnostic capabilities for fast discovery of causes of NOKs
- Standardized interfaces
- Identical signal and data formats

maXYmos BL

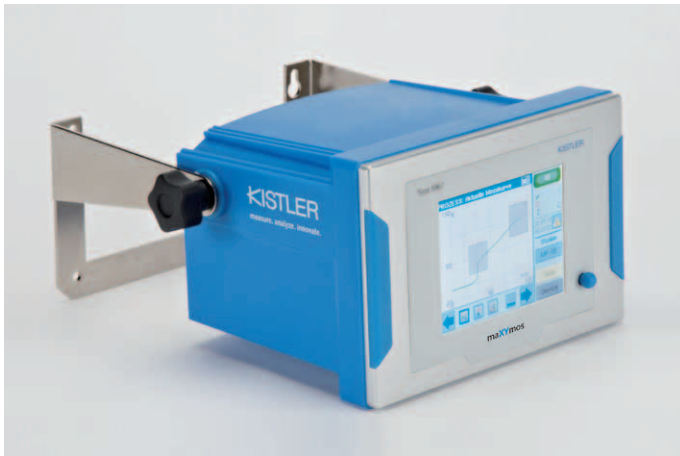

maXYmos BL (Basic Level)

The maXYmos BL is an XY monitor for standard applications in assembly and product testing. This can range from simple spring tests through monitoring of press fitting and testing of damper characteristics. The monitor is equipped with one pair of measuring channels (XY) to evaluate part-specific curves using universal evaluation objects such as UNI-BOX, LINE-X, LINE-Y, NO-Pass and ENVELOPE. Despite the very mod-est price, the user still has access to helpful features such as the curve history memory for NOK diagnostics, table of process values, fieldbus interface for exchange of signals and Ethernet interface for fast data export and remote maintenance. The maXYmos BL can be equipped optionally with the fieldbus Profibus DP or EtherNet/IP.

maXYmos TL



maXYmos TL (Top Level)

This XY monitor can be used for simple force-displacement monitoring all the way through challenging multichannel applications in assembly and product testing. Its functionality and operating concept build upon that of the maXYmos BL.

Key features of the maXYmos TL include more powerful evaluation techniques, a larger selection of sensors, unrestricted choice of fieldbus types, expandability up to 8 pairs of channels and a 10,4" color touch screen display. The monitor is truly ideal in terms of its ease of use and display capabilities. Thanks to additional evaluation objects (GRADIENT, HYSTERESIS and CALCULATE), it can perform optimal evaluation of even complex curve criteria. For example, the CALCULATE object allows

calculation and evaluation of the distance between two breakover points on a force-displacement curve. GETREF objects provide CALCULATE with the positions of these points in advance.

Application Areas

- Assembly monitoring
- Product testing
- Final inspection
- Wear tests
- Production lines
- Manual workstations
- Rotary indexing tables
- Inspection of incoming goods

maXYmos TL screen

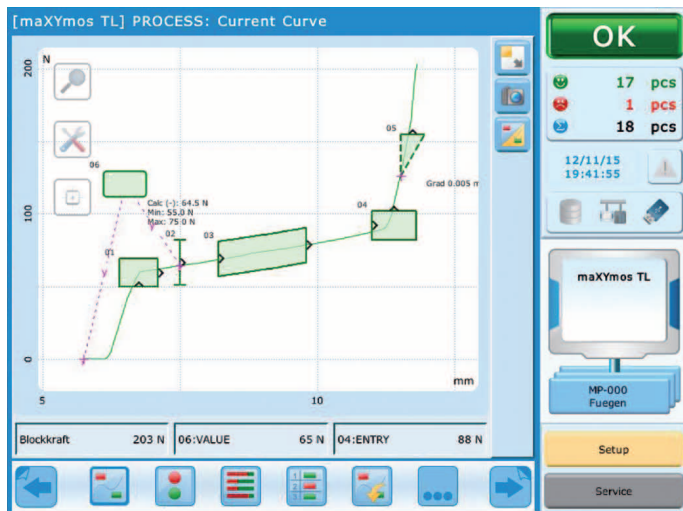

Applications

TL: Contact force	Torque	Press fitting	TL: Snap fitting
BL: Manual presses	Insertion force	Closure	Tactile behavior
Caulking	TL: Rotary switch	TL: Engaging	Riveting

The maXYmos XY Monitors: Models and Selection Criteria

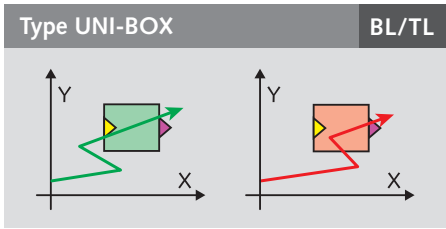

Entry and exit as specified. No crossing of "closed" sides allowed. Each side can be defined as entry or exit.

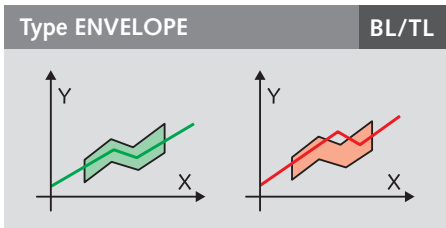

The measurement curve must not cross the upper or lower line of the envelope. This evaluation object is easy to master.

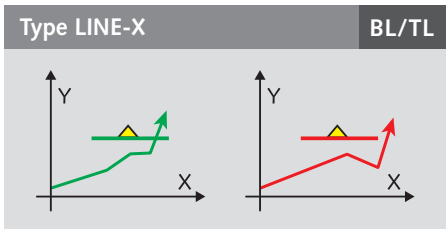

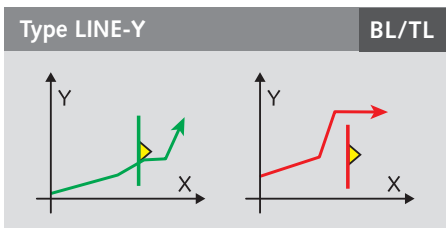

The line must be crossed once. An X-value at the point of intersection is monitored.

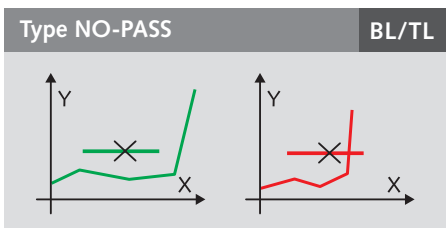

The line must be crossed once. A Y-value at the point of intersection is monitored.



The line may not be crossed. Otherwise, NOK and "NO-PASS" real-time signal

XY monitors			
Type	5867B...	5877A...	
Name	maXYmos BL	maXYmos TL	
Number of measuring channels per base unit	1 x XY	1 x XY	
Measuring channels expandable up to maximum of		8 x XY	
Measurement curve acquisition functions	$y = f(x)$, $y = f(t)$, $y = f(x, t)$, $x = f(t)$	$y = f(x)$, $y = f(t)$, $y = f(x, t)$, $x = f(t)$	
Memory depth per measurement curve	8 000 * XY	8 000 * XY	
Sampling rate (pairs of XY-values / second)	5 000	20 000	
Number of sets of parameters per XY-channel	16	128	
Diagnostic memory for measurement curves	20 curves	500 curves	
Sensor Channel X	Potentiometer	■	■
	Voltage ± 10 V	■	■
	Incremental sin-cos (A, B and Z)		■
	Incremental rectangle (A, B and Z)		■
	SSI		■
	LVTD		■
	Inductive half bridge		■
Sensor channel Y	Piezoelectric	■★	■
	Strain gage	■★	■
	Voltage ± 10 V	■★	■
Evaluation objects for evaluating curve	UNI-BOX (window)	■	■
	Line-X and Line-Y (lines)	■	■
	Envelope	■	■
	NO-PASS (line with online signal)	■	■
	Hysteresis (X + Y)		■
	Gradient		■
	Average (average BOX)		■
	Calc (calculates and evaluates)		■
	Getref (gets reference points)		■
	Speed		■
	Break		■
	Average		■
Tunnelbox		■	
Serial INTFC	Ethernet (TCP/IP)	■	■
	USB	■ (device)	■ (host + device)
Fieldbus	ProfibusDP	■★	■
	ProfiNet		■
	EtherNet/IP	■★	■
	EtherCAT		■
Case models	Front panel (mounting)	■	■
	Wall version	■	■
	Desktop version	■	■
Display	4,5" color touch screen	10,4" color touch screen	
Remote maintenance via	EtherNet using VNC	EtherNet using VNC	
Degree of protection to IEC/EN 60529	IP40, IP65 (mounted on front panel)	IP40, IP65 (mounted on front panel)	
Power supply	24 (18 ... 30) VDC	24 (18 ... 30) VDC	

■ = Standard ★ = Optional

Screen TL: Curve history memory

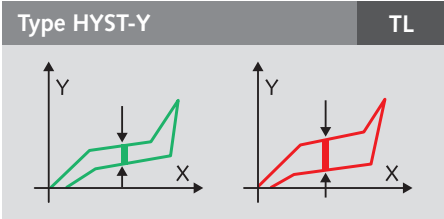
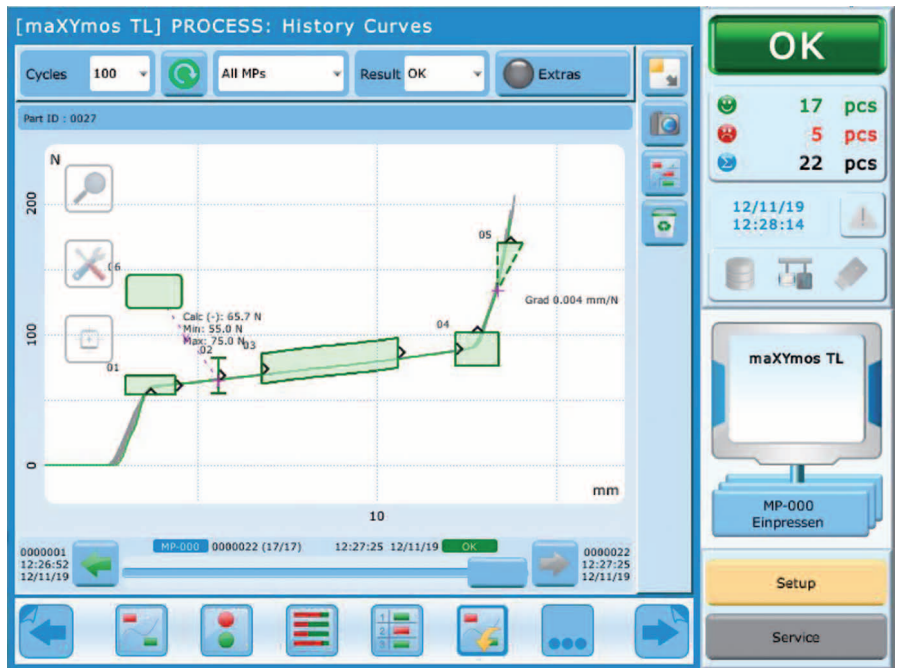

Evaluates the Y-hysteresis between forward and reverse curves on a vertical line

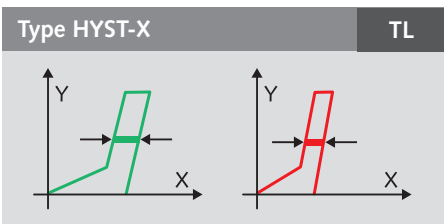

Evaluates the X-hysteresis between forward and reverse curves on a horizontal line



Evaluates the gradient dY/dX between two vertical lines

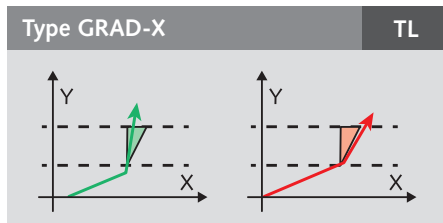

Evaluates the gradient dX/dY between two horizontal lines

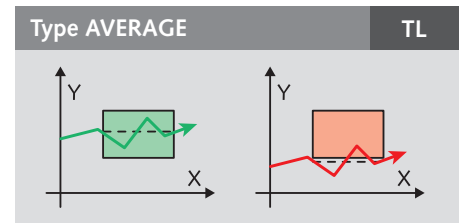

Evaluates the average of all Y-values in the box region

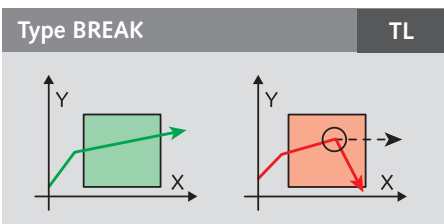

Provides NOK and online signal in case of sudden gradient change within an expectancy range (box), e.g. in case of tool breakage

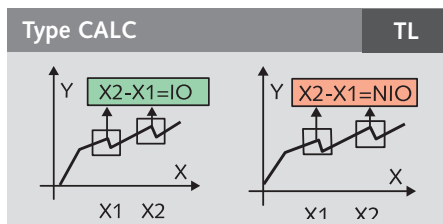

Object references two selectable process values and performs calculations, e.g. the X-difference between two ripples, and evaluates them

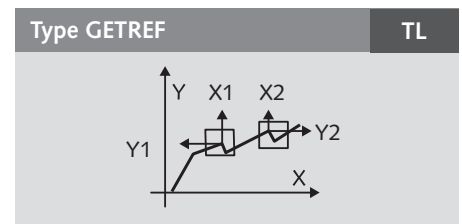

Box detects significant curve features and their XY coordinates in the expectancy range. This information can be used as reference points for other EOs or as an input for the CALC object.

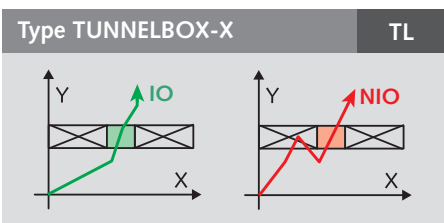

Entry and exit as specified. No crossing of closed sides allowed. Crossing of the „closed“ sides generates a real-time signal.

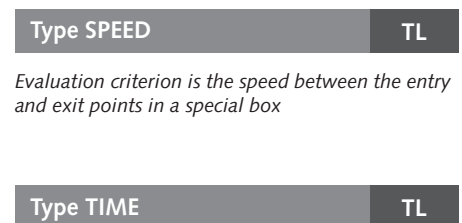
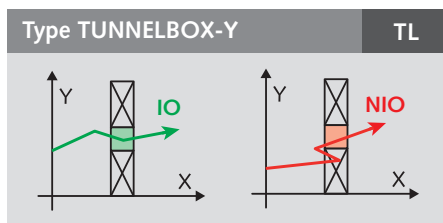

Evaluation criterion is the speed between the entry and exit points in a special box



Evaluation criterion is the time between the entry and exit points in a special box

maXYmos BL

Process Pages and Features

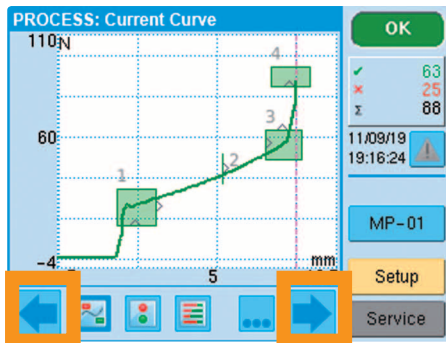

Current measurement curve

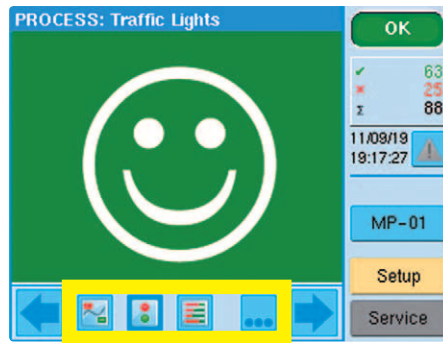

Traffic lights

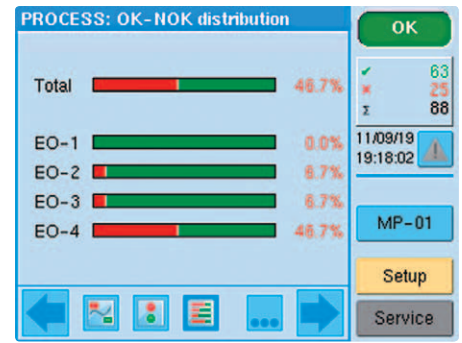

OK/NOK distribution:
Which evaluation object is primarily responsible?

PROCESS: Value Table

EO	Name	Value	Min	Max	Unit
1	ENTRY	-1.0	-1.4	1.1	mm
1	EXIT	30	17	35	N
2	ENTRY	41	37	52	N
3	ENTRY	51	49	64	N
3	EXIT	9.7	8.0	10.3	mm
4	YMAX-Y	83	85	94	N

Results and process values

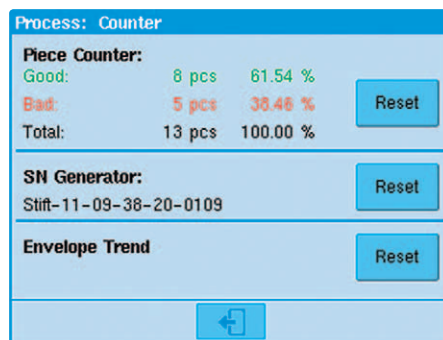

Piece counter

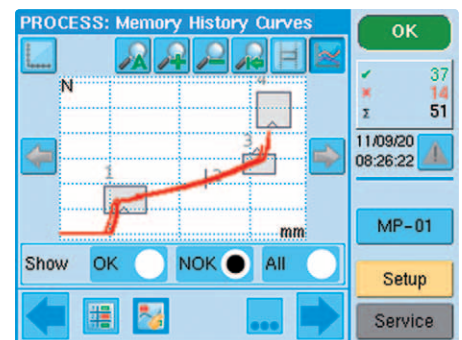

NOK diagnostics: "Last measurement curves" memory

Important maXYmos BL Features at a Glance

- Curve evaluation using envelope curves, boxes and thresholds
- 4 evaluation objects per curve and measurement program
- Monitoring of up to 10 parts per second
- 16 measurement programs for 16 different types of part
- Up to 8 000 pairs of X/Y-values per curve
- 3 real-time outputs for X- and Y-thresholds
- Dig-IO (24 V), Profibus DP, Ethernet TCP/IP and USB
- Memory for historical measurement curves for NOK diagnosis
- Warning and alarm messages allowing early countermeasures
- Serial numbers from PLC or internal S/N generator
- Access protection for different user groups
- Channel X: potentiometer and ±10 V, channel Y: piezoelectric or strain gage / ±10 V
- Bright, high-contrast 3,5" color touch screen display
- Clearly structured user interface
- General-purpose case for panel, wall and desktop mounting
- PC software "maXYmos PC" as support tool
- Extremely good value for money

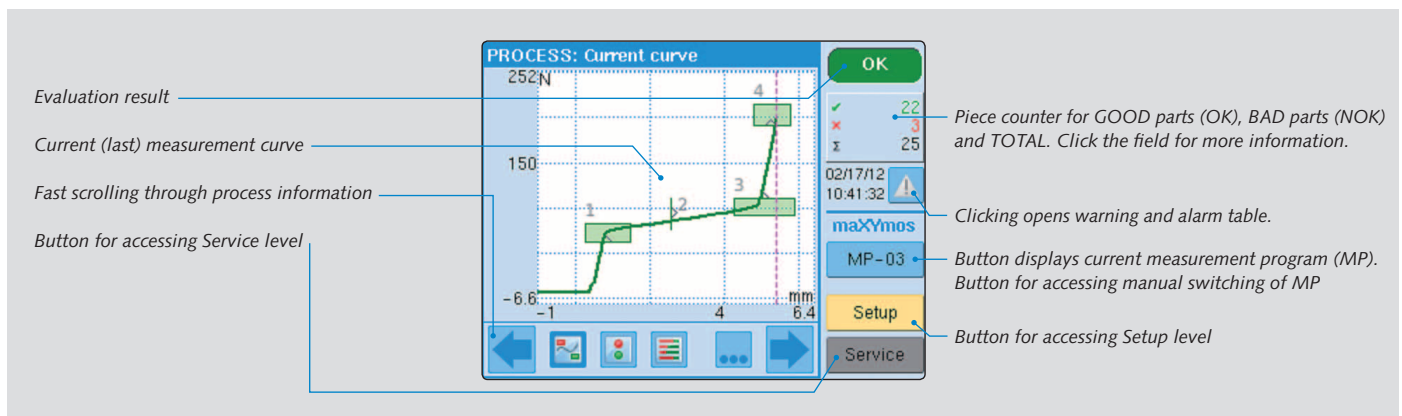

Main menu for Process level: Starting point for process information and other menu levels

maXYmos TL

Process Pages and Features

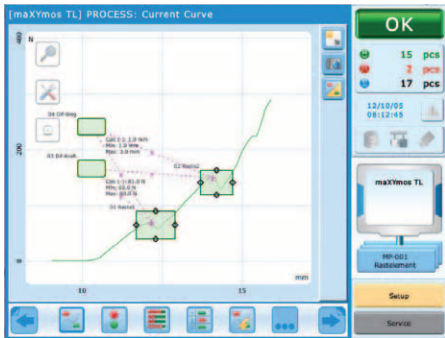

Application in product testing: Distance check between two breakover points of a fixing element. GETREF boxes provide the coordinates of the points to the CALCULATE objects. They in turn compute and evaluate the relevant distances in the force and displacement direction (current measurement curve).

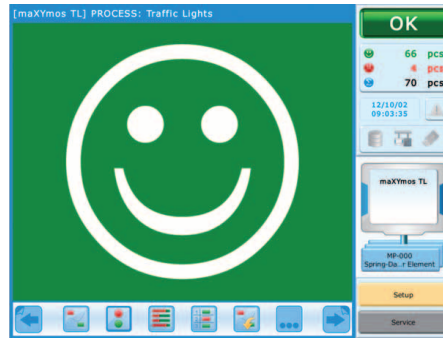

Traffic lights

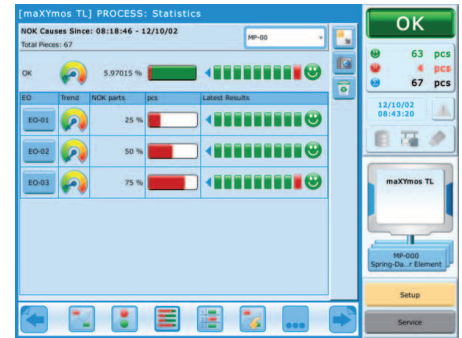

OK/NOK distribution:
Which evaluation object is primarily responsible?

EO	Name	Value	min	max	Unit
EO-01 (UNI-BOX)	ENTRY	9.2	5.9	6.7	mm
EO-01 (UNI-BOX)	EXIT	74	45	69	N
EO-02 (ENVELOPE)	ENTRY	86	58	76	N
EO-03 (UNI-BOX)	YMIN-X	10.8	10.8	11.6	mm
EO-03 (UNI-BOX)	YMIN-Y	97	80	104	N

Results and process values

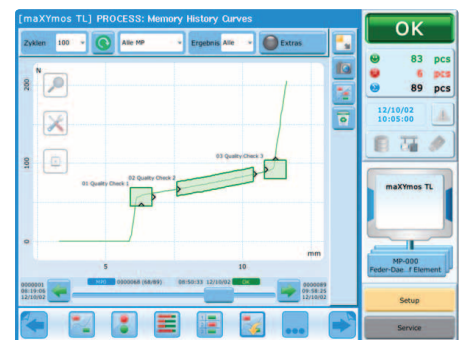

Curve history memory

Important maXYmos TL Features at a Glance

- Monitoring of up to 20 parts per second
- 128 measurement programs for 128 types of part
- Up to 8 000 pairs of XY-values per measurement curve
- Measurement curve acquisition at up to 20 000 samples/s
- Real-time outputs for rapid response
- Powerful tools for diagnosing the causes of NOKs
- Diagnostic memory for up to 500 measurement curves with bundle function
- Warning and alarm messages allowing early countermeasures
- Cascadable to up to 8 pairs of XY-channels
- Serial numbers from PLC or internal S/N generator

- Access protection for different user groups
- Channel X: potentiometer, ± 10 V, incremental encoder, LVDT or SSI, inductive half bridge, channel Y: piezoelectric, strain gage or ± 10 V
- Profibus DP, ProfiNet, EtherNet/IP and EtherCat
- Bright, high-contrast 10,4" color touch screen display
- Clearly structured user interface
- PC software "maXYmos PC" as support tool

maXYmos BL/TL Equipment and System Concept

The flexible case concept of the maXYmos XY monitors allows easy integration into existing or newly planned systems. Retrofitting of presses (automatic or manually operated) is also very simple.

Both monitor types employ a universal case concept. A minimum of manipulation is required to convert between the desktop, wall-mounting and panel installation versions.

maXYmos BL

As the basic version, the maXYmos BL is optimized for mounting in a front panel. An optional additional case allows mounting on a vertical panel of a machine or on a flat surface as well as continuous adjustment of the angle of inclination. The operator can use the adjusting screws on both sides to set the desired view angle.

maXYmos TL

The maXYmos TL consists primarily of two components: the measuring and evaluation

module (MEM) and the display module (DIM). The two components can either be installed separately at different locations so they are only connected via the monitor cable, or they can function as a single compact mechanical and electrical unit. The latter configuration is achieved by inserting the MEM into the rear slot of the DIM. This combination already provides one pair of measuring channels (XY) and all of the interfaces required for control, data export and remote maintenance. If continual visualization is not required, the MEM can also function as a black box module and the user interface can be displayed on a PC (provided by the customer) or operator panel by using a VNC client.

Desktop and Wall Version

The mounting bracket attached to the DIM module can be used to convert the device from the desktop version to the wall version with a minimum of manipulation.

It is also possible to separate the measuring and evaluation module (MEM) from the display module (DIM) and arrange it at a remote position, e.g. in the switch cabinet. Advantages: Only a monitor cable is connected to the display. At the same time, the degree of protection in the area of the monitor is increased to IP65.

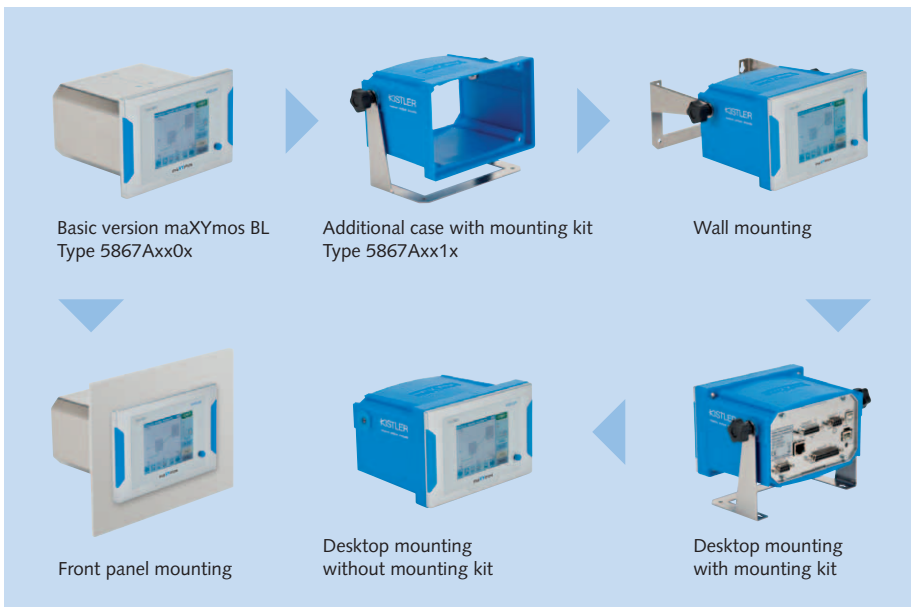

maXYmos BL



maXYmos TL Front panel mounting (panel version) Attachment using removable frame

Wall mounting

Desktop mounting

maXYmos TL Equipment and System Concept

Panel Version for Front Panel Mounting

After removing the mounting bracket and rear frame from the display module, the display is inserted through the front-panel opening and the frame is screwed back into place. If necessary, the measuring module (MEM) can also be inserted into the display module's slot.



Display module (DIM, left), measuring and evaluation module (MEM, right)

MEM as Pure Black Box Module

Setup and process visualization are then handled using VNC access via the Ethernet interface or in conjunction with the maXYmos PC software available as an accessory via the USB interface. A maXYmos TL system can be easily expanded to handle up to 8 pairs of channels (XY). The MEMs are connected to the Ethernet interface using patch cables. No external switches are required since the Ethernet connection is looped through the MEMs using in/out connectors.



Compact electrical and mechanical unit (top), separate installation of both components with a connection via the monitor cable (bottom)

Using an optional top hat rail clip, the MEM can be housed in a protected manner in a switch cabinet. If necessary, it is then possible to visualize the individual measurement channels via a display module outside of the switch cabinet.

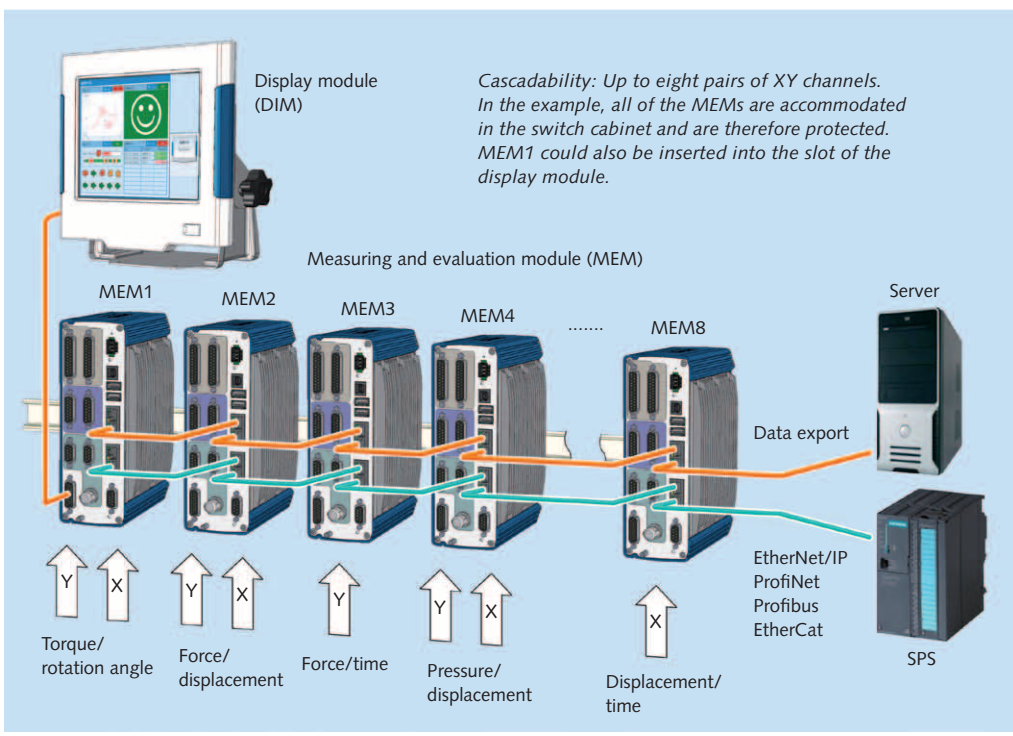

Interfaces

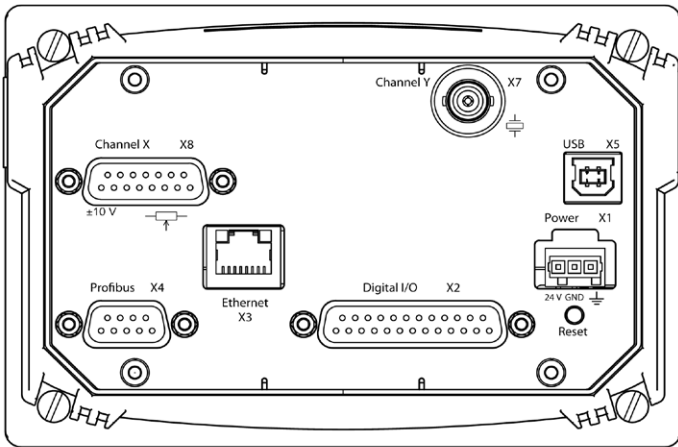

maXYmos BL: Back panel piezoelectric version (with Profibus)

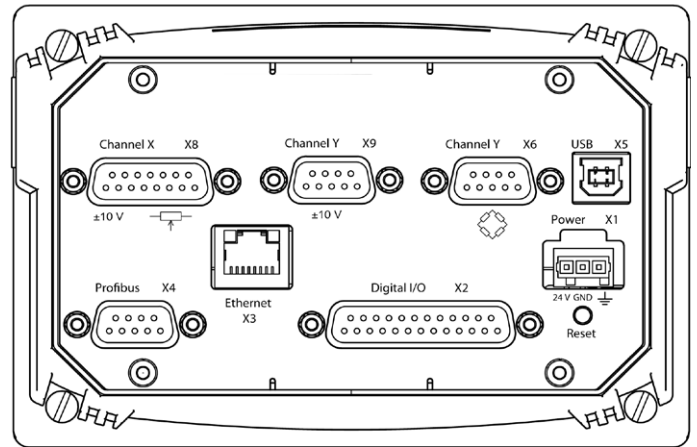

maXYmos BL: Back panel strain gage version (with Profibus)

The maXYmos XY monitors are characterized by a consistent operating concept as well as consistent interfaces. The available interfaces are compatible on the pin and signal levels. This applies to the available sensor systems as well as the digital control signals.

maXYmos BL

The maXYmos BL is available in four versions. The Y-channel is available in a piezoelectric version and a strain gage/±10 V version. Potentiometric displacement and angle sensors as well as sensors with a ±10 V output for the X-channel are supported by both types. Besides choosing between the piezoelectric and strain gage versions, the user must also select one of the bus versions (Profibus or Ethernet IP).

maXYmos TL

In terms of the variety of possible interfaces, the measuring and evaluation module (MEM) also meets practically every need. All of the most common interfaces are always available for quick selection in the menu. This allows the user to respond quickly to changing requirements in the area of sensor and fieldbus types. The cost of maintaining an inventory of spare parts is also reduced: Thanks to the "one for all" principle, only one type needs to be maintained on hand.

For the Y-channel, there is an input for piezoelectric sensors as well as an interface for strain gage sensors and sensors with a ±10 V output. For the X-channel, inputs are installed for analog sensors (potentiometer, ±10 V, LVDT, inductive) and digital sensors (incremental, SSI). This allows flexible selection of the connected sensor system depending on the particular meas-

uring task at hand, and no definitive choice is required in advance. USB and Ethernet TCP/IP interfaces are provided for communications and for exporting data. Various fieldbus versions (Profibus DP, EtherNet/IP, Profinet, EtherCat) can be used to communicate with the machine or system. These versions are installed on the MEM module and can be selected via the device's software.

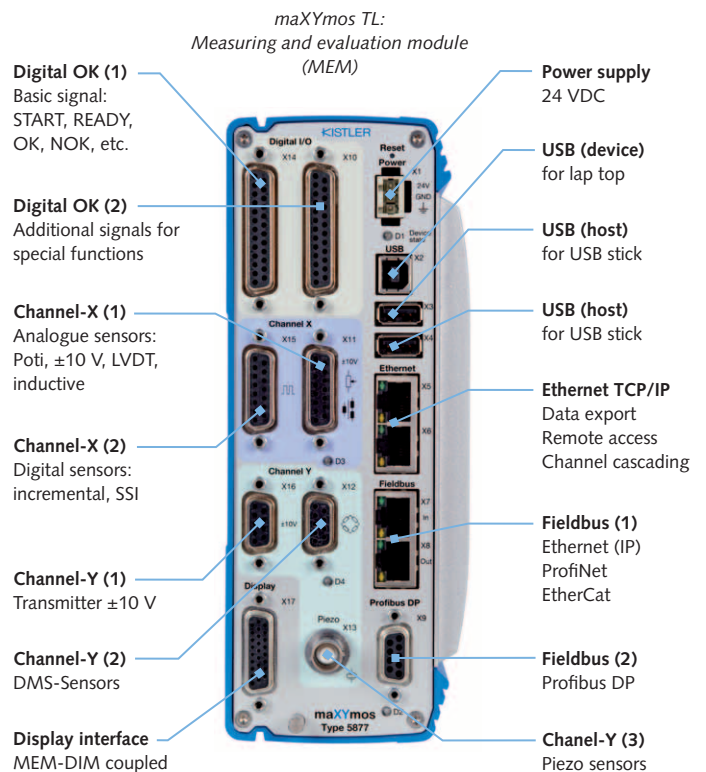

Compatible Sensors, maXYmos PC Software

Sensors

For operation with the maXYmos monitors, Kistler offers a wide selection of force and torque sensors based on the piezoelectric or strain gage measuring principle as well as potentiometric displacement and angle sensors:

Piezoelectric Sensors

Tension/compression force:

0 ... ±0,5 N to 0 ... ±300 kN

Compression force:

0 ... 0,1 N to 0 ... 800 kN

Strain (indirect measurement):

up to 800 µε

Torque (static):

0 ... ±0,25 N·m to 0 ... ±200 N·m

Potentiometric Sensors

Displacement: 0 ... 10 mm to 0 ... 750 mm

Rotation angle: 0 ... 360 °

Strain Gage Sensors

Tension/compression force:

0 ... ±20 N to 0 ... ±500 kN

Compression force: 0 ... 20 N to 0 ... 200 kN

Torque (rotating):

0 ... ±2 N·m to 0 ... ±1 000 N·m



The maXYmos family has XY monitors that are suitable for every application along with appropriate sensors – all from a single source.

Software maXYmos PC

Windows® Software maXYmos PC (Basic)*

- Organize firmware updates
- Save device settings as file (backup)
- Reload device settings from file (restore)

Windows® Software maXYmos PC (Plus)

Like basic version but also includes the following:

- Open, view and edit backup files
- Manage complete device settings on PC (setup editor)
- Explorer opens and interprets exported test records
- Cursor measurement, curve bundle display, etc.
- Display completed Y(X) curves also as Y(t) or X(t)
- Generation of Excel® statistics file with selected process values
- PDF print function for test records

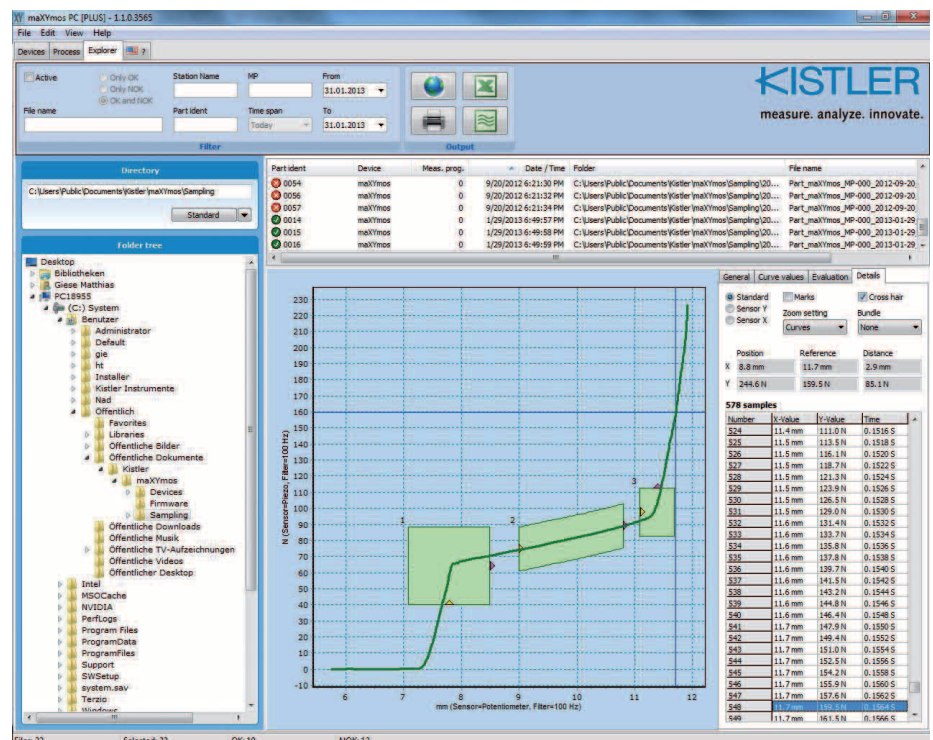

maXYmos PC Plus: File explorer for visualizing and analyzing measurement curves

* Included with product

Windows® and Microsoft Excel® are registered trademarks of Microsoft Corporation.

Kistler Worldwide

Europe

Austria

Kistler GmbH
1230 Wien
Tel. +43 1 867 48 67 0
sales.at@kistler.com

Czech Republic/Hungary/ Poland/Slovakia

Kistler, s.r.o.
140 00 Praha 4
Tel. +420 296 374 878
sales.cz@kistler.com

Denmark

Kistler Nordic DK
4681 Herfølge
Tel. +45 70 20 85 66
info.dk@kistler.com

Finland

Kistler Nordic AB
00210 Helsinki
Tel. +358 9 612 15 66
info.fi@kistler.com

France

Kistler France
91953 Les Ulis cedex
Tel. +33 1 69 18 81 81
info.fr@kistler.com

Germany

Kistler Instrumente GmbH
73760 Ostfildern
Tel. +49 711 34 07 0
info.de@kistler.com

Italy

Kistler Italia s.r.l.
20149 Milano
Tel. +39 02 481 27 51
sales.it@kistler.com

Netherlands

Kistler B.V. Nederland
2811 DT Reeuwijk
Tel. +31 182 304 444
sales.nl@kistler.com

Spain

Kistler Ibérica S.L, Unipersonal
08402 Granollers, Barcelona
Tel. +34 93 860 33 24
info.es@kistler.com

Sweden/Norway

Kistler Nordic AB
431 53 Mölndal
Tel. +46 31 871 566
info.se@kistler.com

Switzerland/Liechtenstein

Kistler Instrumente AG
8408 Winterthur
Tel. +41 52 224 12 32
sales.ch@kistler.com

United Kingdom

Kistler Instruments Ltd.
Hook, Hampshire RG27 9GR
Tel. +44 1256 74 15 50
sales.uk@kistler.com

Asia

China, People's Republic of

Kistler China Ltd.
Hong Kong
Tel. +852 25 915 930
sales.cn@kistler.com

India

Kistler Instruments (India) Pvt. Ltd.
Faridabad – 121 007, Haryana
Tel. +91 129 4113 555
sales.in@kistler.com

Japan

Kistler Japan Co., Ltd.
Tokyo 108-0022
Tel. +81 3 3769 9501
sales.jp@kistler.com

Korea, Republic of

Kistler Korea Co., Ltd.
Anyang-City, Gyeonggi-Do 430-731
Tel. +82 31 465 6013
sales.kr@kistler.com

Singapore

Kistler Instruments (Pte) Ltd.
Singapore 573968
Tel. +65 6570 5377
sales.sg@kistler.com

Taiwan

Kistler Instrumente AG, Taiwan Branch
Taipei 114
Tel. +886 2 7721 2121
sales.tw@kistler.com

Thailand

Kistler Instrument (Thailand) Co., Ltd.
Bangkok 10120
Tel. +66 2678 6779-80
sales.thai@kistler.com

America

Brasil

Kistler Brasil Ltda
CEP 040 28-001, São Paulo-SP Brasil
Tel. +55 11 50520308
sales.br@kistler.com

Mexico

Kistler Instruments S de RL de CV.
Apodaca, NL. 66629
Tel. +52 81 4170 8075
sales.mx@kistler.com

USA/Canada

Kistler Instrument Corp.
Novi, MI 48377
Tel. +1 248 668 6900
sales.us@kistler.com

Australia

Australia

Kistler Instruments Australia Pty Ltd
Wheelers Hill, Victoria 3150
Tel. +61 3 9560 5055
sales.au@kistler.com

Other Countries

Kistler Instrumente AG
Export Sales
Eulachstrasse 22, 8408 Winterthur
Switzerland
Tel. +41 52 224 11 11
sales.export@kistler.com

Headquarters

Switzerland

Kistler Group
Eulachstrasse 22, 8408 Winterthur
Tel. +41 52 224 11 11
Fax +41 52 224 14 14
info@kistler.com

www.kistler.com

KISTLER

measure. analyze. innovate.