

# Surface Strain Sensor

## for Indirect Measurement of Process Forces

Type 9237B ...

Patent No. US 7,694,577 B2

This robust strain sensor is particularly suitable for measuring dynamic and quasistatic forces on stationary or moving machine parts. For this purpose it uses force-proportional strain on machine or structural surfaces for indirect force measurement.

- Wide range for tension and compression forces
- High sensitivity allows accurate measurement of minute strains
- Overload-proof design
- Robust industrial construction (IP67)
- Easy mounting with just one screw

### Description

The strain of the basic material acts via the two contact surfaces on the sensor as a change in distance. The sensor housing serves as an elastic transmission element that converts this change into a force. The piezoelectric elements in shear generate an electric charge  $Q$  [pC] proportional to the force.

The particular advantages of piezotechnology over the familiar foil strain gage technology are high sensitivity, substantial overload resistance, virtually unlimited service life and high load cycle stability.

The measurement signal can be processed as a relative value. For absolute value measurements (e.g. in N or kN) the strain sensor must be calibrated against an appropriate reference.

The design of the sensor and its stainless steel housing allow it to be used in industrial environments. The Type 9237B20 e.g. with cable Type 1915A... provides an IP67 protection level for use in wet and dirty situations.

The integral KIAG 10-32 neg. connector accommodates a broad selection of connecting cables (see notes on accessories).



### Applications

The sensor Type 9237B... can be used for monitoring all types of machinery with a gap frame, such as mechanical presses and automatic assembly machines, and its ease of mounting makes it ideal for retrofitting. Application sectors include:

- Machine monitoring, such as protecting mechanical presses against overload
- Quality assurance in production runs for joining process such as wobble riveting, clinching and resistance spot welding
- Monitoring machine tools, such as prompt detection of tool breakage or tool collision

### Technical Data

Measuring range	$\mu\epsilon$	-800 ... 800
Calibrated measuring range	$\mu\epsilon$	0 ... 500
Mechanical overload capacity	$\mu\epsilon$	$\pm 1\ 000$
Nominal sensitivity	pC/ $\mu\epsilon$	$\approx -34$
Linearity	%/FSO	$\leq \pm 2$
Operating temperature range	$^{\circ}\text{C}$	-30 ... 120
Weight	g	$\approx 160$
Protection rating (EN 60529) with cable connected		IP65/IP67 <sup>1)</sup>
Connector		KIAG 10-32 neg.

<sup>1)</sup> IP67 for Type 9237B20 with cable Type 1915A... only

**Dimensions**

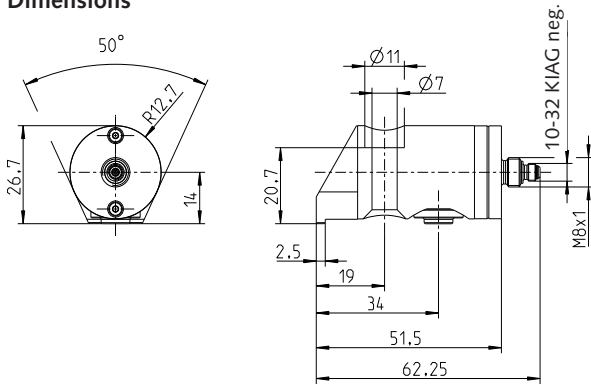

Fig. 1: Type 9237B10

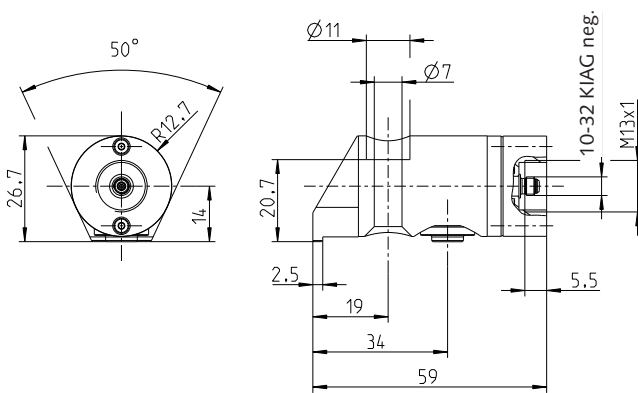

Fig. 2: Type 9237B20 with M13x1 adapter for protective hose

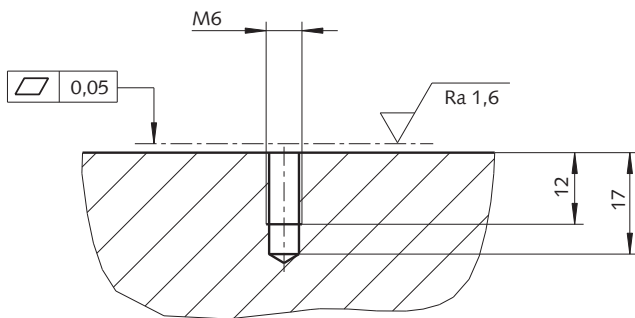

Fig. 3: Preparing the mounting surface

**Mounting**

- Machine the surface at the measuring point (N7; Ra 1,6 microns) and tap the M6 female thread (see Figure 3).
- Align the sensor on the structure of the machine. Position the measuring axis so as to record the maximum strain (Figure 4).
- The sensor is secured with a single screw with pre-greased thread and head bearing surface. Preload this screw with a torque of 14 N·m (Figure 5).
- The cable run close to the sensor should be as free from tension or compression as possible. Transmission of cable movements or vibration to the sensor must be avoided.

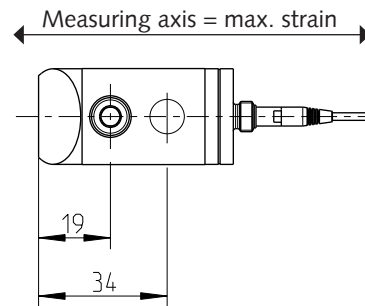

Fig. 4: Aligning sensor to the strain axis

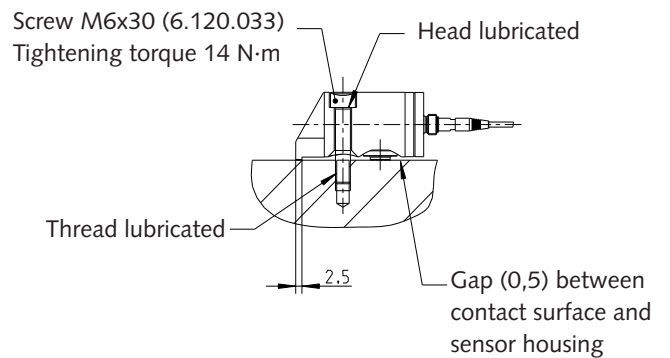





Fig. 5: Mounting with 6-point socket head cap screw

9237A\_000-823e-01.11

**Example of a Measuring Chain**

		
<p>Strain sensor Type 9237B10</p>	<p>Cable Type 1983AD</p>	<p>Charge amplifier ICAM Type 5073A111</p>

**Typical Application**

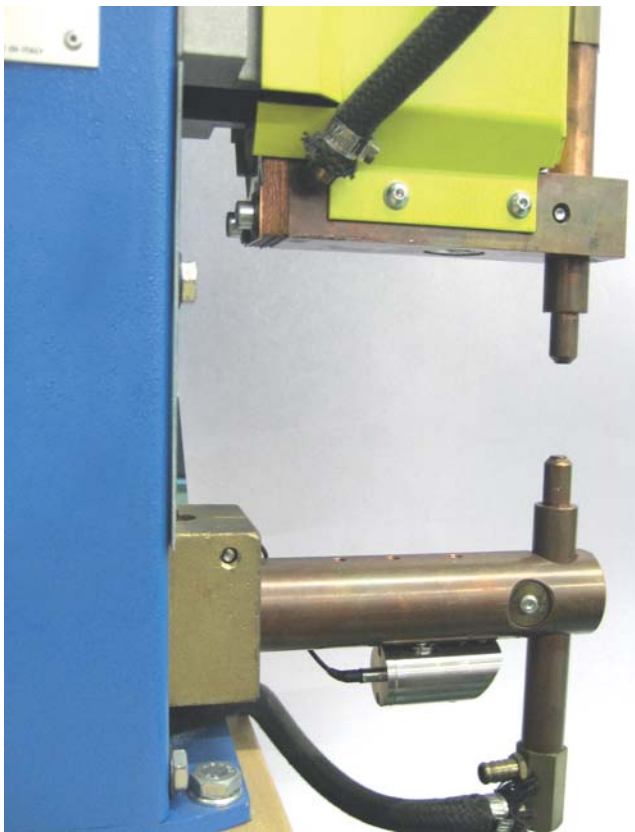

Fig. 6: Indirect measurement of electrode clamping force on a spot welding machine with strain sensor Type 9237B10

**Included Accessories**

- 6-point socket head cap screw, M6x30

**Type/Art. No.**

6.120.033

**Optional Accessories**

- Various highly insulated connecting cables with KIAG 10-32 pos. connector, such as
- High-temperature connecting cable in sealed protective hose

**Type/Art. No.**

1983A...  
1939A...  
1979A...  
etc.  
1915A1

**Ordering Key**

**Connection**

Connection KIAG 10-32 neg.	1
Connection KIAG 10-32 neg. with M13x1 adapter for protective tube	2

**Ground-Isolated Model**

No (standard)	0
Yes (optional, not yet available at date of publication)	1

Type 9237B

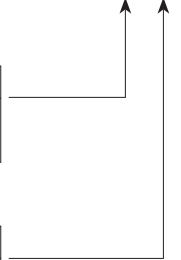

9237A\_000-823e-01.11